

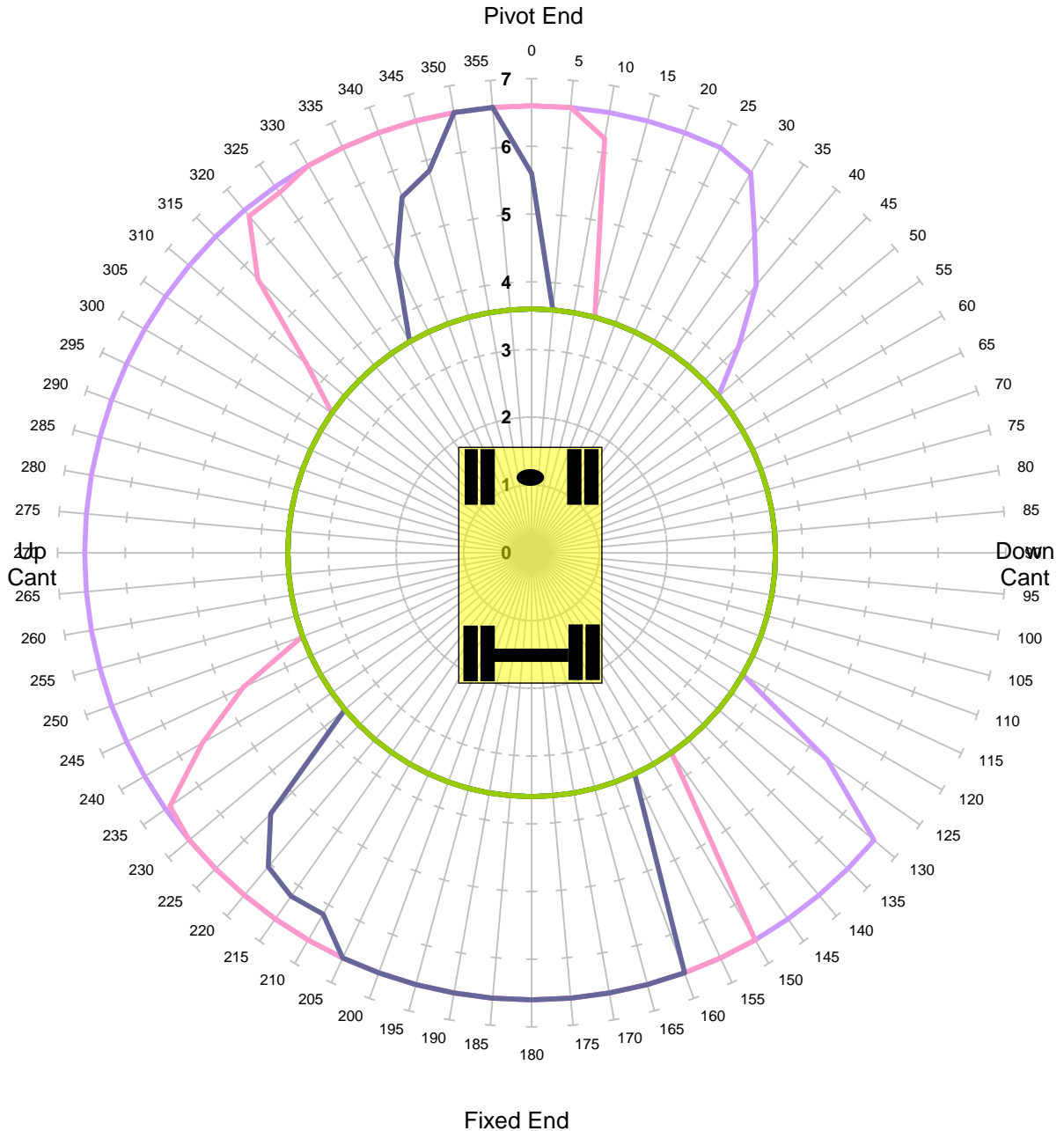

KING TRANSPORT EQUIPMENT LTD
Max Capacity Contours of Radius(m) Plots 2.1m Dipper
Gradient 1 in -25 Height 2m Lift BP
Unlocked Rail Cant -150mm



Units in Tonnes

- 1
- 2
- 3
- 4
- 5
- 6
- 7
- 8
- 9
- 10

| | | | |
|-----------------------------|--------------|-----------------------|----------------|
| MACHINE & MODEL: | Case 988 | REFERENCE: | 99709 940608-1 |
| SERIAL No: | CGG0232265 | DATE OF CHART: | 27-Jan-2022 |
| EQUIPMENT: | 4.29m + 2.1m | SAFETY FACTOR: | 67.0% |
| COMMENT: | | | |



KING TRANSPORT EQUIPMENT LTD
Max Capacity Contours of Radius(m) Plots 2.1m Dipper
Gradient 1 in -25 Height 2m Lift BP
Unlocked Rail Cant -50mm

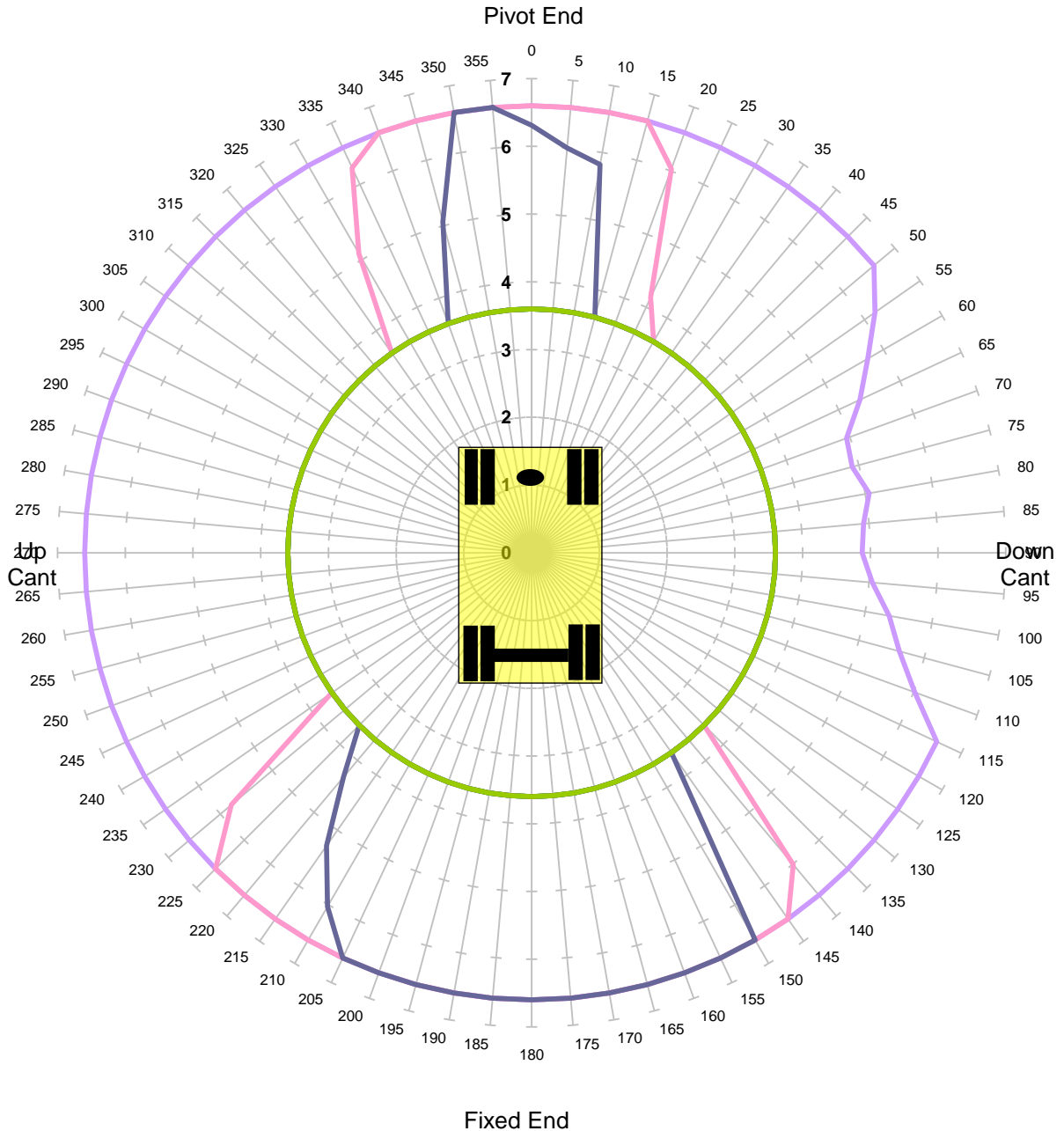

Units in Tonnes

- 1
- 2
- 3
- 4
- 5
- 6
- 7
- 8
- 9
- 10

| | | | |
|-----------------------------|--------------|-----------------------|----------------|
| MACHINE & MODEL: | Case 988 | REFERENCE: | 99709 940608-1 |
| SERIAL No: | CGG0232265 | DATE OF CHART: | 27-Jan-2022 |
| EQUIPMENT: | 4.29m + 2.1m | SAFETY FACTOR: | 67.0% |
| COMMENT: | | | |



KING TRANSPORT EQUIPMENT LTD
Max Capacity Contours of Radius(m) Plots 2.1m Dipper
Gradient 1 in -25 Height 2m Lift BP
Unlocked Rail Cant 50mm

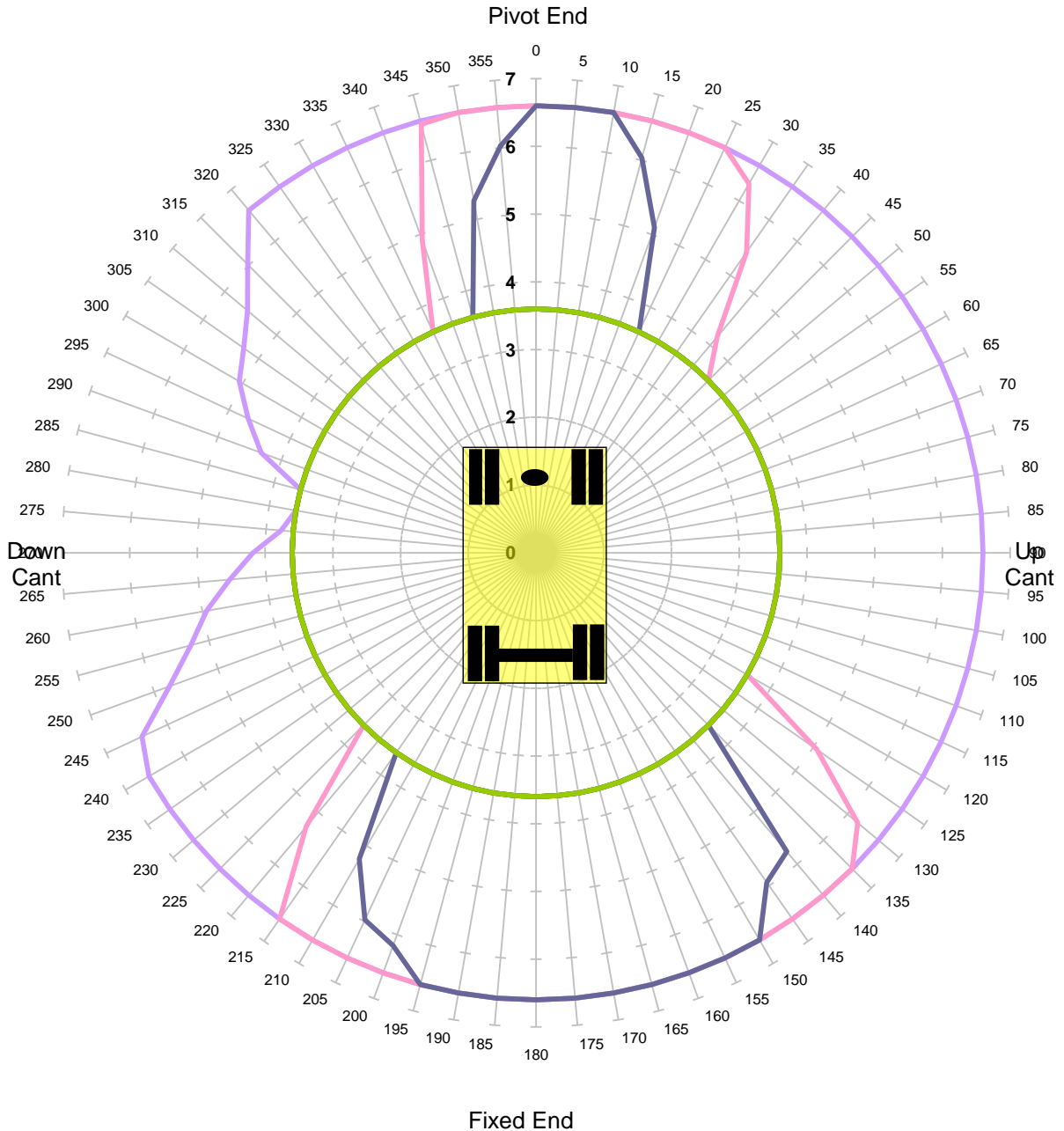

Units in Tonnes

- 1
- 2
- 3
- 4
- 5
- 6
- 7
- 8
- 9
- 10

| | | | |
|-----------------------------|--------------|-----------------------|----------------|
| MACHINE & MODEL: | Case 988 | REFERENCE: | 99709 940608-1 |
| SERIAL No: | CGG0232265 | DATE OF CHART: | 27-Jan-2022 |
| EQUIPMENT: | 4.29m + 2.1m | SAFETY FACTOR: | 67.0% |
| COMMENT: | | | |



KING TRANSPORT EQUIPMENT LTD
Max Capacity Contours of Radius(m) Plots 2.1m Dipper
Gradient 1 in -25 Height 2m Lift BP
Unlocked Rail Cant 150mm

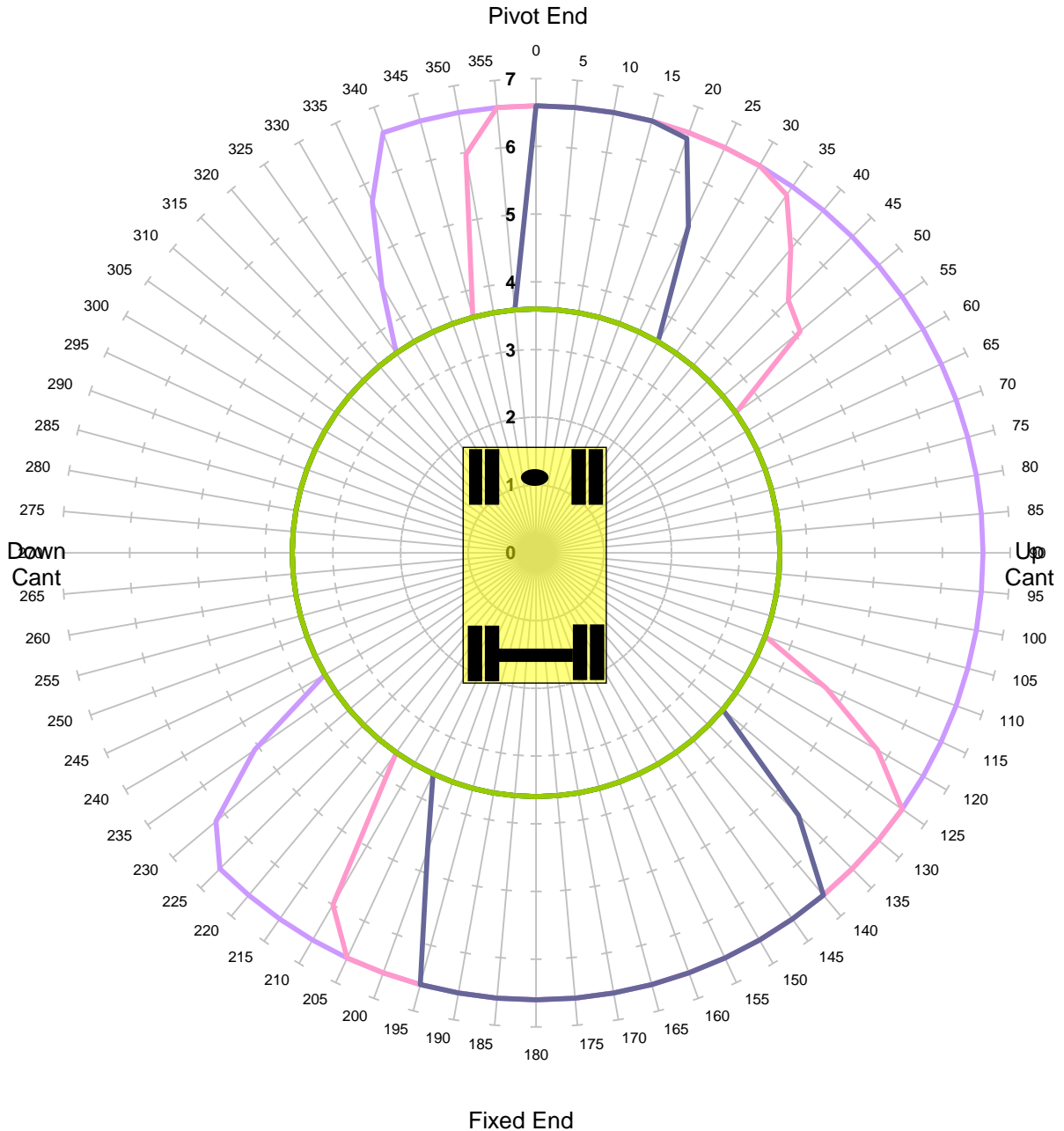

Units in Tonnes

- 1
- 2
- 3
- 4
- 5
- 6
- 7
- 8
- 9
- 10

| | | | |
|-----------------------------|--------------|-----------------------|----------------|
| MACHINE & MODEL: | Case 988 | REFERENCE: | 99709 940608-1 |
| SERIAL No: | CGG0232265 | DATE OF CHART: | 27-Jan-2022 |
| EQUIPMENT: | 4.29m + 2.1m | SAFETY FACTOR: | 67.0% |
| COMMENT: | | | |



KING TRANSPORT EQUIPMENT LTD
Max Capacity Contours of Radius(m) Plots 2.1m Dipper
Gradient 1 in -25 Height 2m Lift BP
Locked Rail Cant -150mm

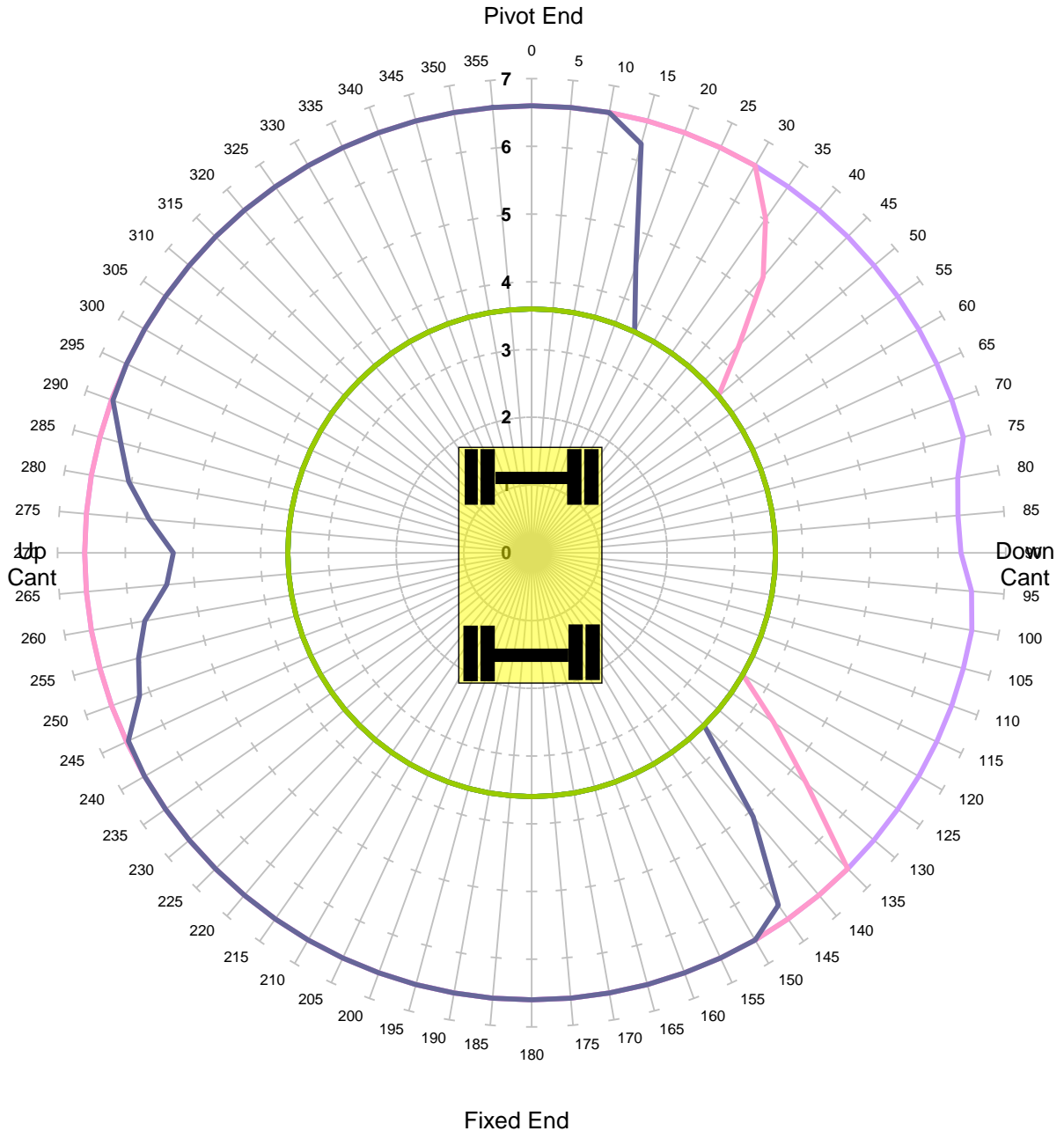

Units in Tonnes

- 1
- 2
- 3
- 4
- 5
- 6
- 7
- 8
- 9
- 10

| | | | |
|-----------------------------|--------------|-----------------------|----------------|
| MACHINE & MODEL: | Case 988 | REFERENCE: | 99709 940608-1 |
| SERIAL No: | CGG0232265 | DATE OF CHART: | 27-Jan-2022 |
| EQUIPMENT: | 4.29m + 2.1m | SAFETY FACTOR: | 90.0% |
| COMMENT: | | | |



KING TRANSPORT EQUIPMENT LTD
Max Capacity Contours of Radius(m) Plots 2.1m Dipper
Gradient 1 in -25 Height 2m Lift BP
Locked Rail Cant -50mm

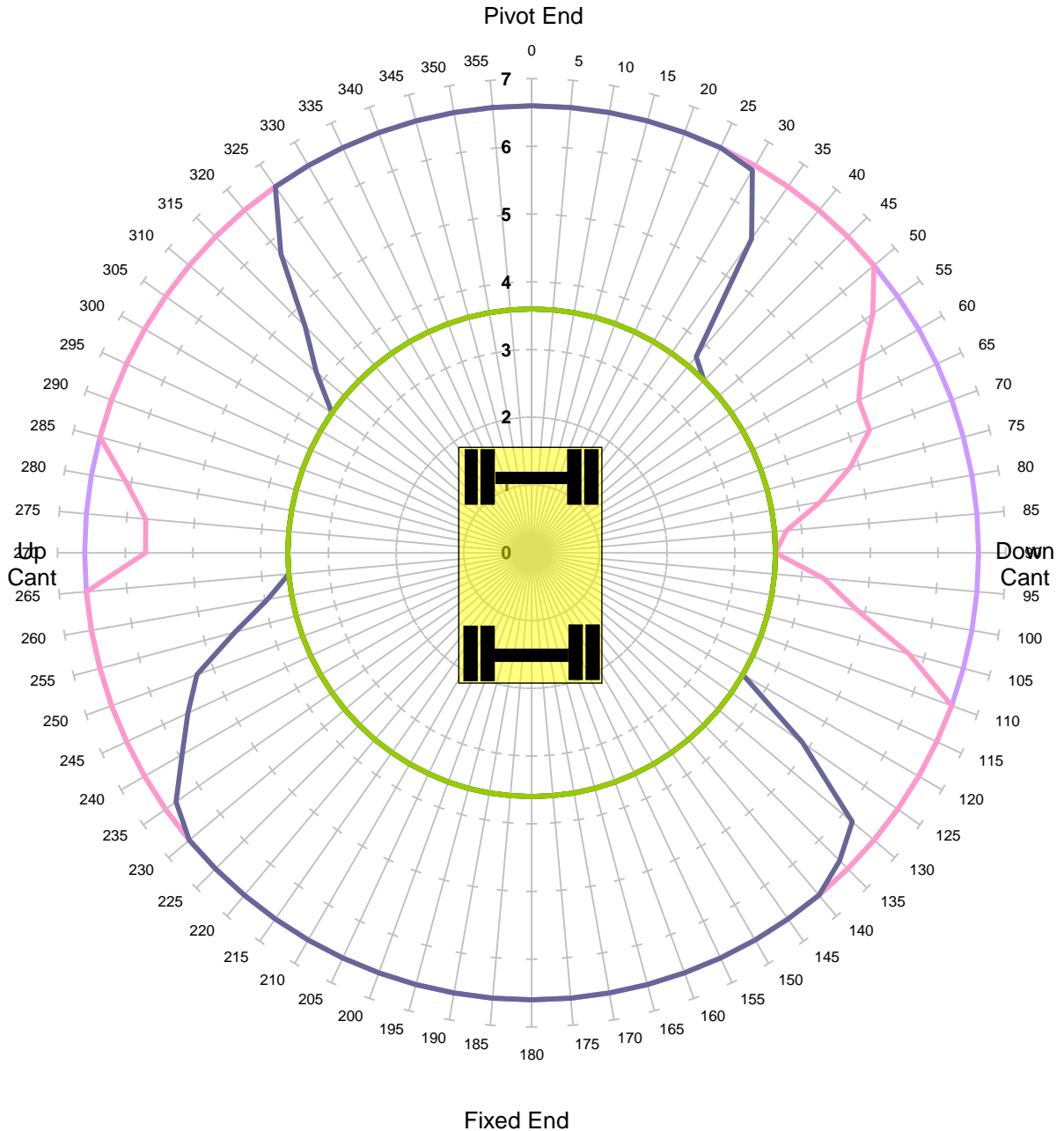

Units in Tonnes

- 1
- 2
- 3
- 4
- 5
- 6
- 7
- 8
- 9
- 10

| | | | |
|-----------------------------|--------------|-----------------------|----------------|
| MACHINE & MODEL: | Case 988 | REFERENCE: | 99709 940608-1 |
| SERIAL No: | CGG0232265 | DATE OF CHART: | 27-Jan-2022 |
| EQUIPMENT: | 4.29m + 2.1m | SAFETY FACTOR: | 90.0% |
| COMMENT: | | | |



KING TRANSPORT EQUIPMENT LTD
Max Capacity Contours of Radius(m) Plots 2.1m Dipper
Gradient 1 in -25 Height 2m Lift BP
Locked Rail Cant 50mm

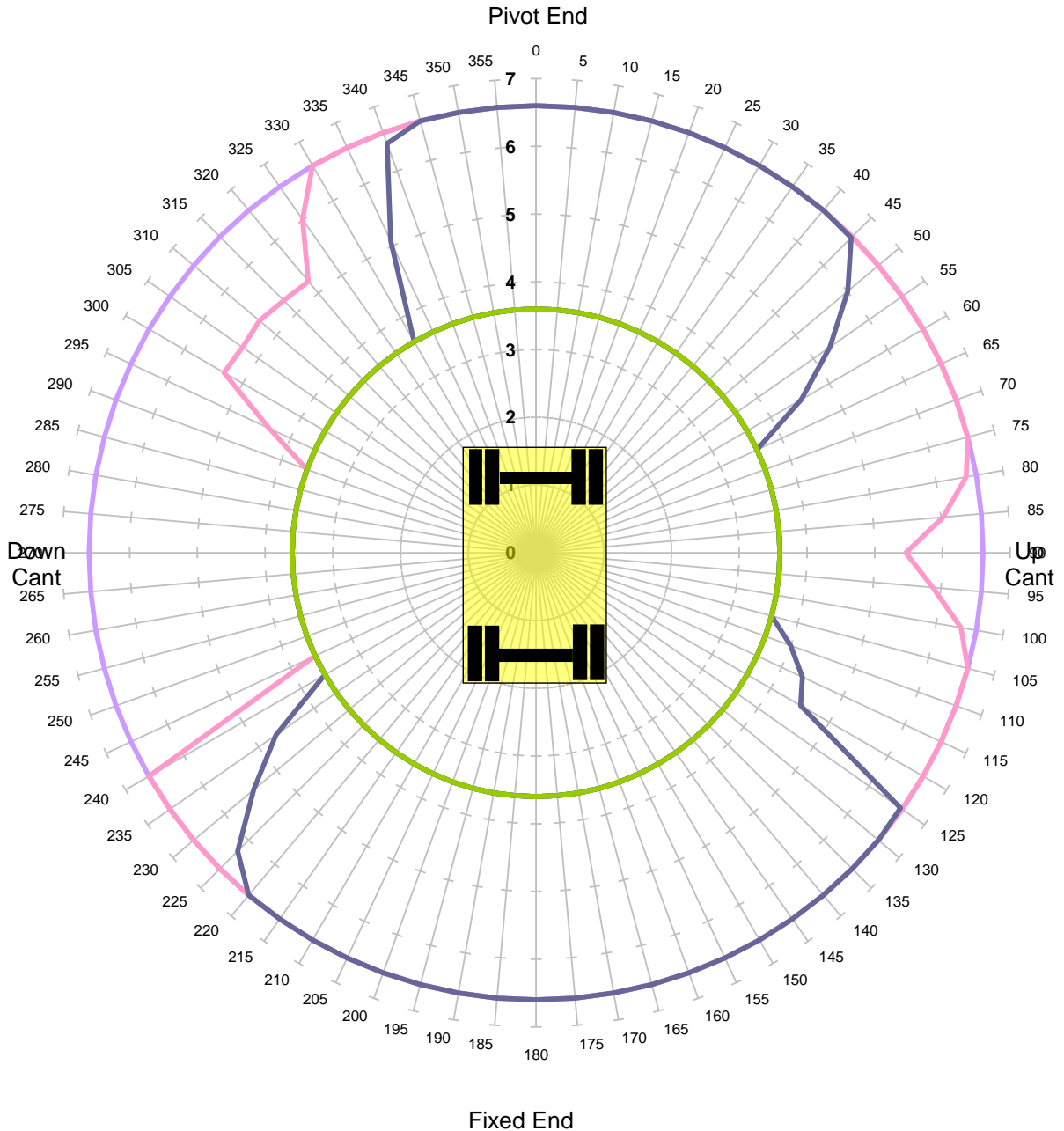

Units in Tonnes

- 1
- 2
- 3
- 4
- 5
- 6
- 7
- 8
- 9
- 10

| | | | |
|-----------------------------|--------------|-----------------------|----------------|
| MACHINE & MODEL: | Case 988 | REFERENCE: | 99709 940608-1 |
| SERIAL No: | CGG0232265 | DATE OF CHART: | 27-Jan-2022 |
| EQUIPMENT: | 4.29m + 2.1m | SAFETY FACTOR: | 90.0% |
| COMMENT: | | | |



KING TRANSPORT EQUIPMENT LTD
Max Capacity Contours of Radius(m) Plots 2.1m Dipper
Gradient 1 in -25 Height 2m Lift BP
Locked Rail Cant 150mm

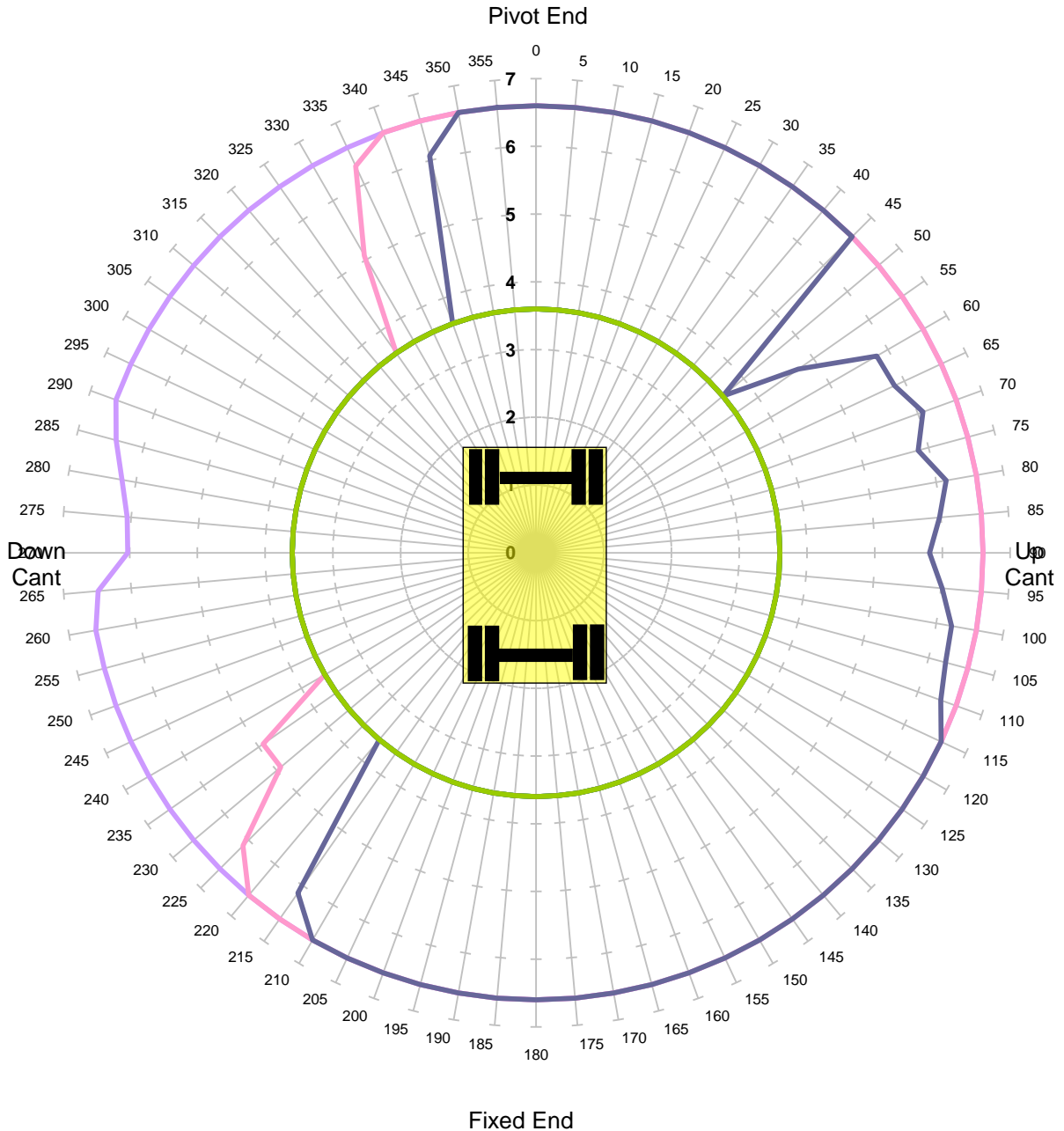

Units in Tonnes

- 1
- 2
- 3
- 4
- 5
- 6
- 7
- 8
- 9
- 10

| | | | |
|-----------------------------|--------------|-----------------------|----------------|
| MACHINE & MODEL: | Case 988 | REFERENCE: | 99709 940608-1 |
| SERIAL No: | CGG0232265 | DATE OF CHART: | 27-Jan-2022 |
| EQUIPMENT: | 4.29m + 2.1m | SAFETY FACTOR: | 90.0% |
| COMMENT: | | | |



KING TRANSPORT EQUIPMENT LTD
Max Capacity Contours of Radius(m) Plots 2.1m Dipper
Level Ground Height 2m Lift BP
Unlocked Road

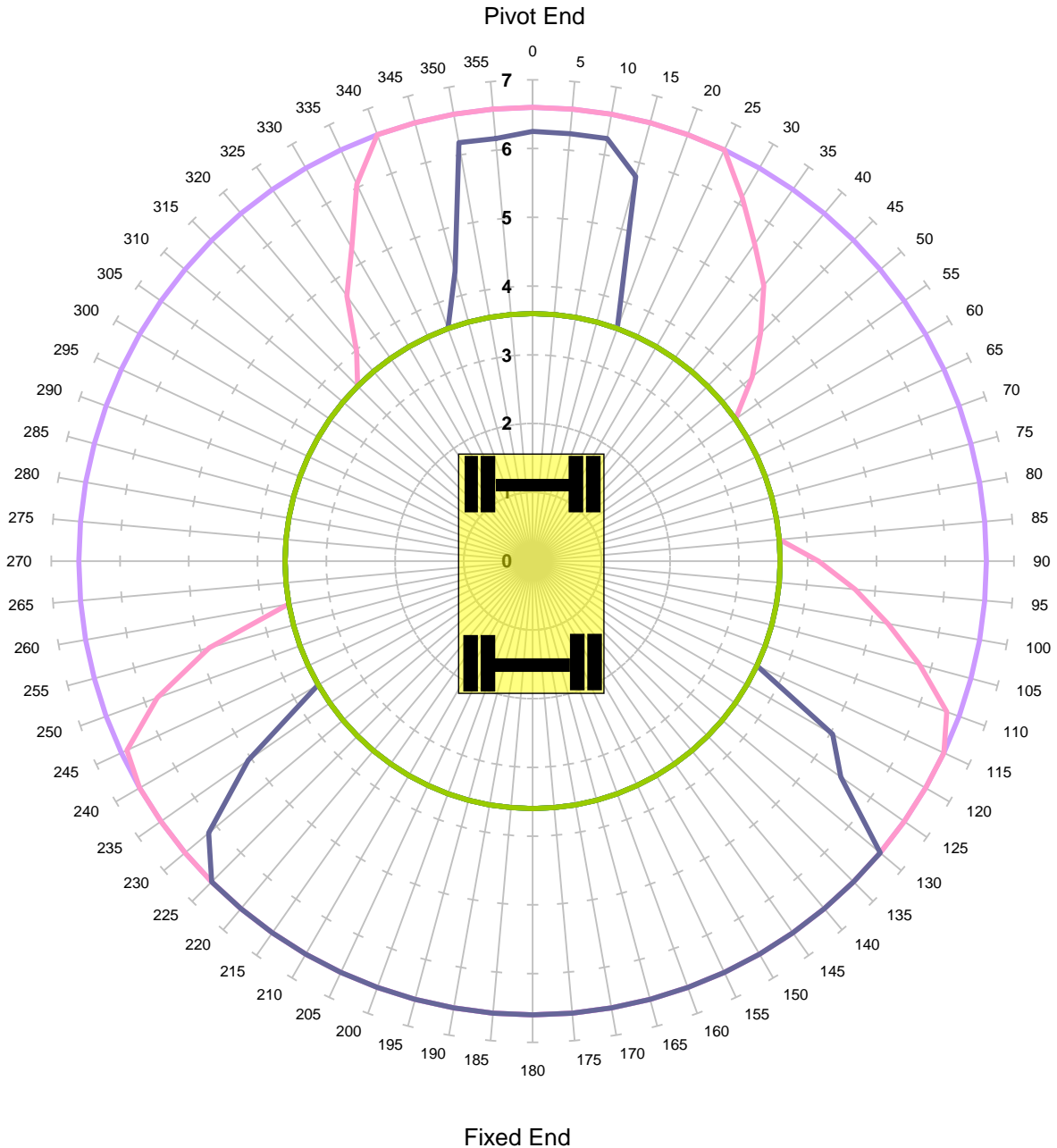

Units in Tonnes

- 1
- 2
- 3
- 4
- 5
- 6
- 7
- 8
- 9
- 10

| | | | |
|-----------------------------|--------------|-----------------------|----------------|
| MACHINE & MODEL: | Case 988 | REFERENCE: | 99709 940608-1 |
| SERIAL No: | CGG0232265 | DATE OF CHART: | 27-Jan-2022 |
| EQUIPMENT: | 4.29m + 2.1m | SAFETY FACTOR: | 75.0% |
| COMMENT: | | | |



KING TRANSPORT EQUIPMENT LTD
Max Capacity Contours of Radius(m) Plots 2.1m Dipper
Level Ground Height 2m Lift BP
Locked Road

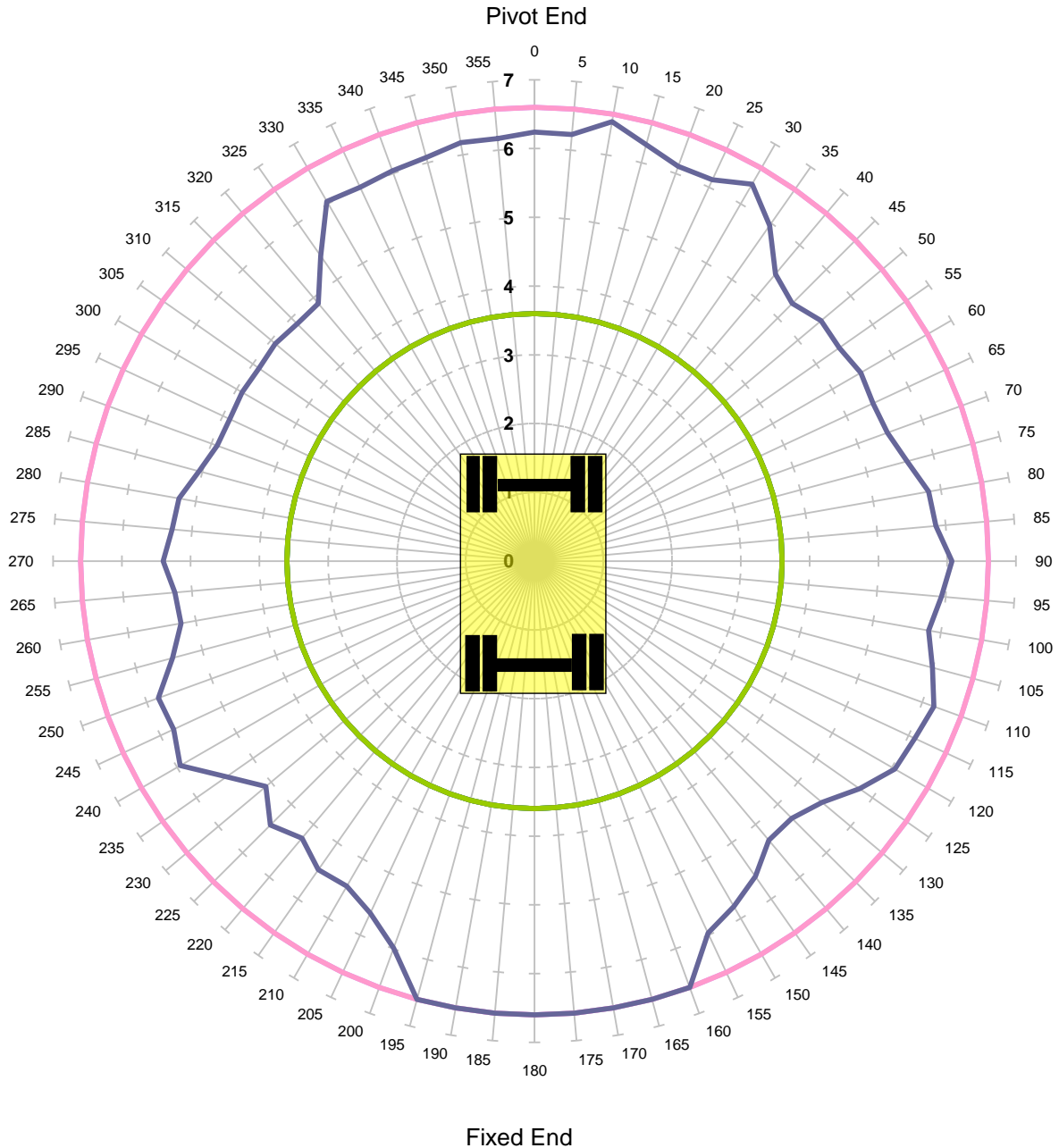

Units in Tonnes

- 1
- 2
- 3
- 4
- 5
- 6
- 7
- 8
- 9
- 10

| | | | |
|-----------------------------|--------------|-----------------------|----------------|
| MACHINE & MODEL: | Case 988 | REFERENCE: | 99709 940608-1 |
| SERIAL No: | CGG0232265 | DATE OF CHART: | 27-Jan-2022 |
| EQUIPMENT: | 4.29m + 2.1m | SAFETY FACTOR: | 75.0% |
| COMMENT: | | | |



KING TRANSPORT EQUIPMENT LTD
Max Capacity Contours of Radius(m) Plots 2.1m Dipper
Gradient 1 in -25 Height 2m Lift BP
Unlocked Rail Cant -150mm - Tandem Lift

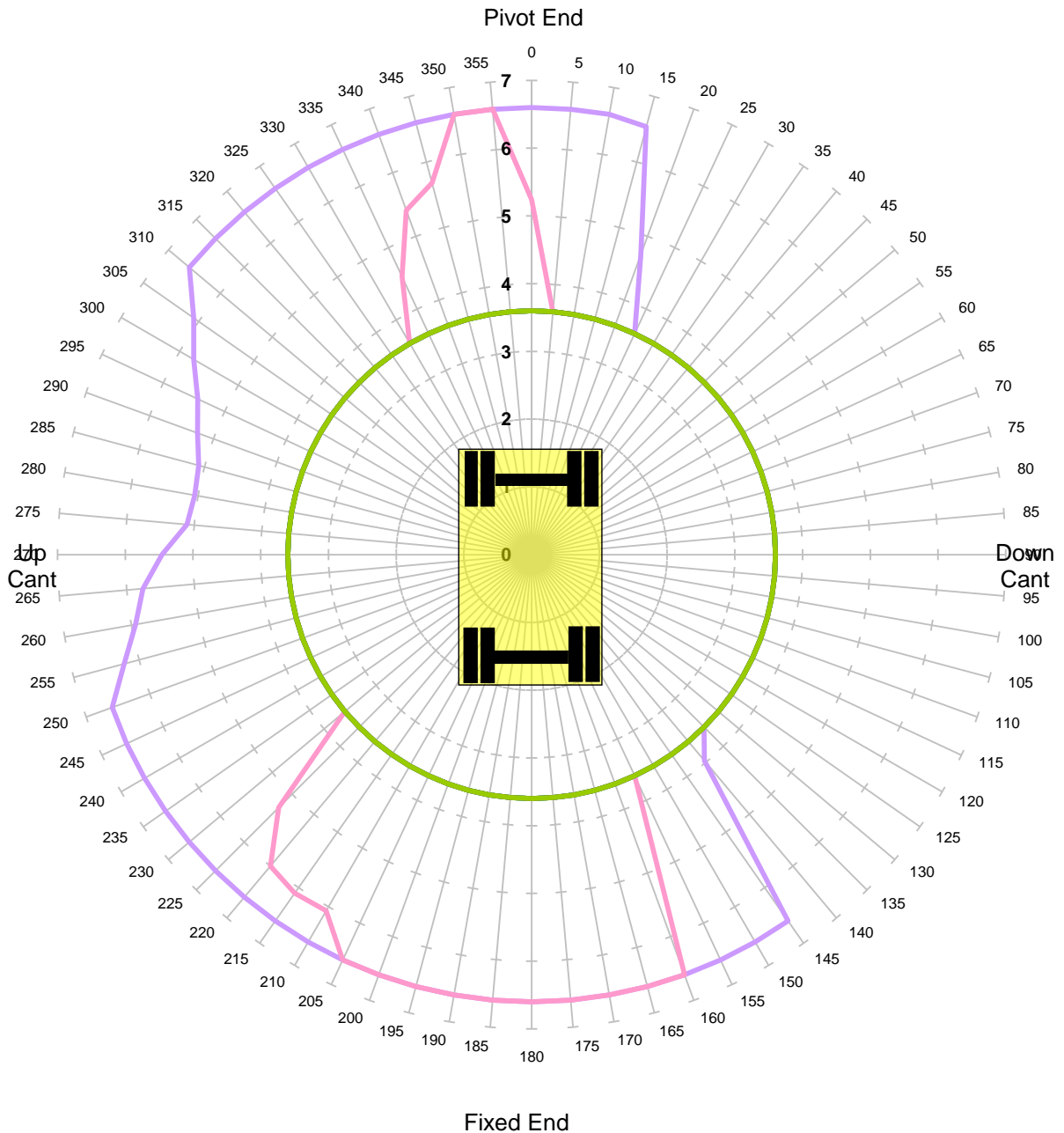

Units in Tonnes

- 1
- 2
- 3
- 4
- 5
- 6
- 7
- 8
- 9
- 10

| | | | |
|-----------------------------|--------------|-----------------------|----------------|
| MACHINE & MODEL: | Case 988 | REFERENCE: | 99709 940608-1 |
| SERIAL No: | CGG0232265 | DATE OF CHART: | 27-Jan-2022 |
| EQUIPMENT: | 4.29m + 2.1m | SAFETY FACTOR: | 44.0% |
| COMMENT: | | | |



KING TRANSPORT EQUIPMENT LTD
Max Capacity Contours of Radius(m) Plots 2.1m Dipper
Gradient 1 in -25 Height 2m Lift BP
Unlocked Rail Cant -50mm - Tandem Lift

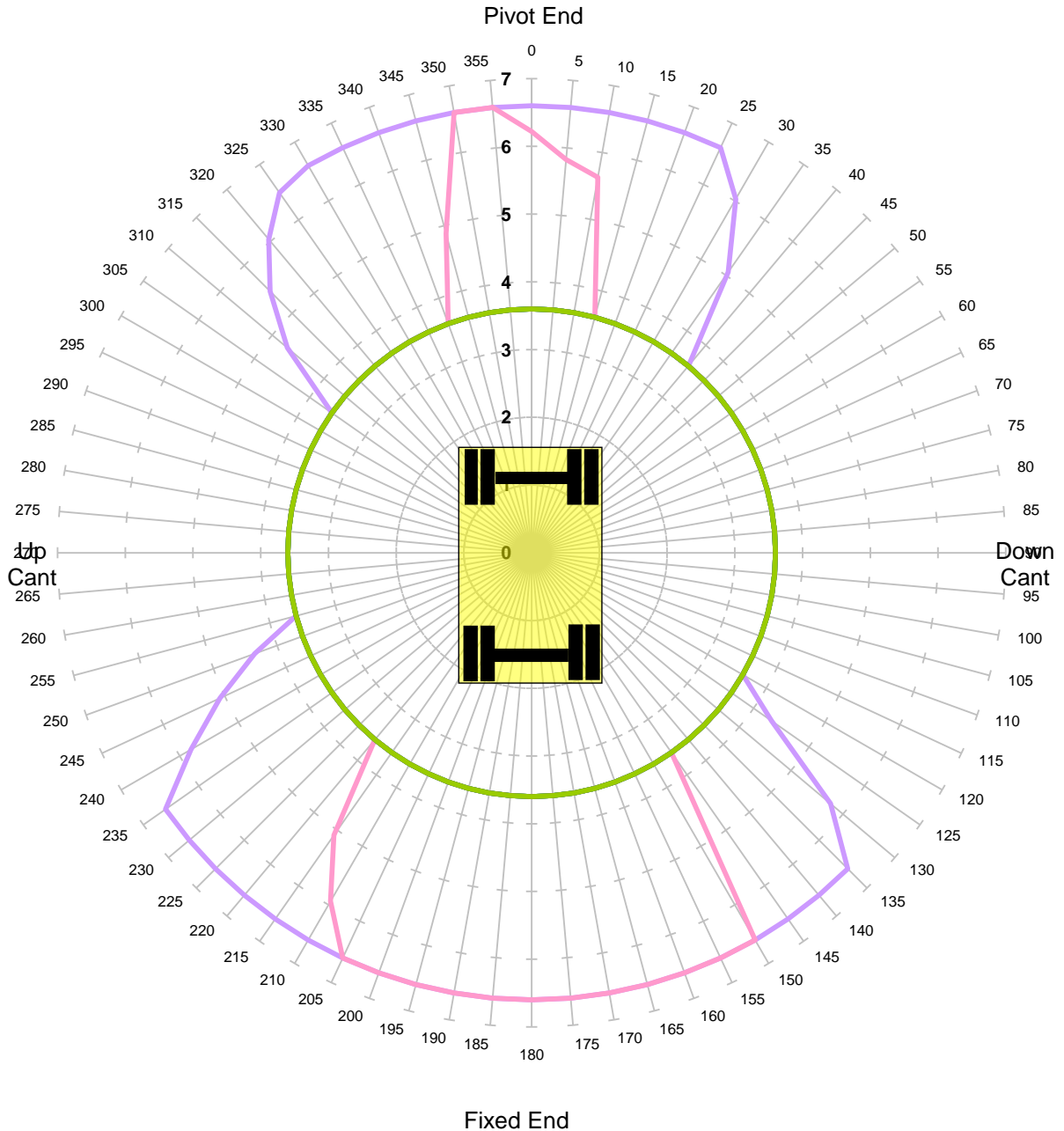

Units in Tonnes

- 1
- 2
- 3
- 4
- 5
- 6
- 7
- 8
- 9
- 10

| | | | |
|-----------------------------|--------------|-----------------------|----------------|
| MACHINE & MODEL: | Case 988 | REFERENCE: | 99709 940608-1 |
| SERIAL No: | CGG0232265 | DATE OF CHART: | 27-Jan-2022 |
| EQUIPMENT: | 4.29m + 2.1m | SAFETY FACTOR: | 44.0% |
| COMMENT: | | | |



KING TRANSPORT EQUIPMENT LTD
Max Capacity Contours of Radius(m) Plots 2.1m Dipper
Gradient 1 in -25 Height 2m Lift BP
Unlocked Rail Cant 50mm - Tandem Lift

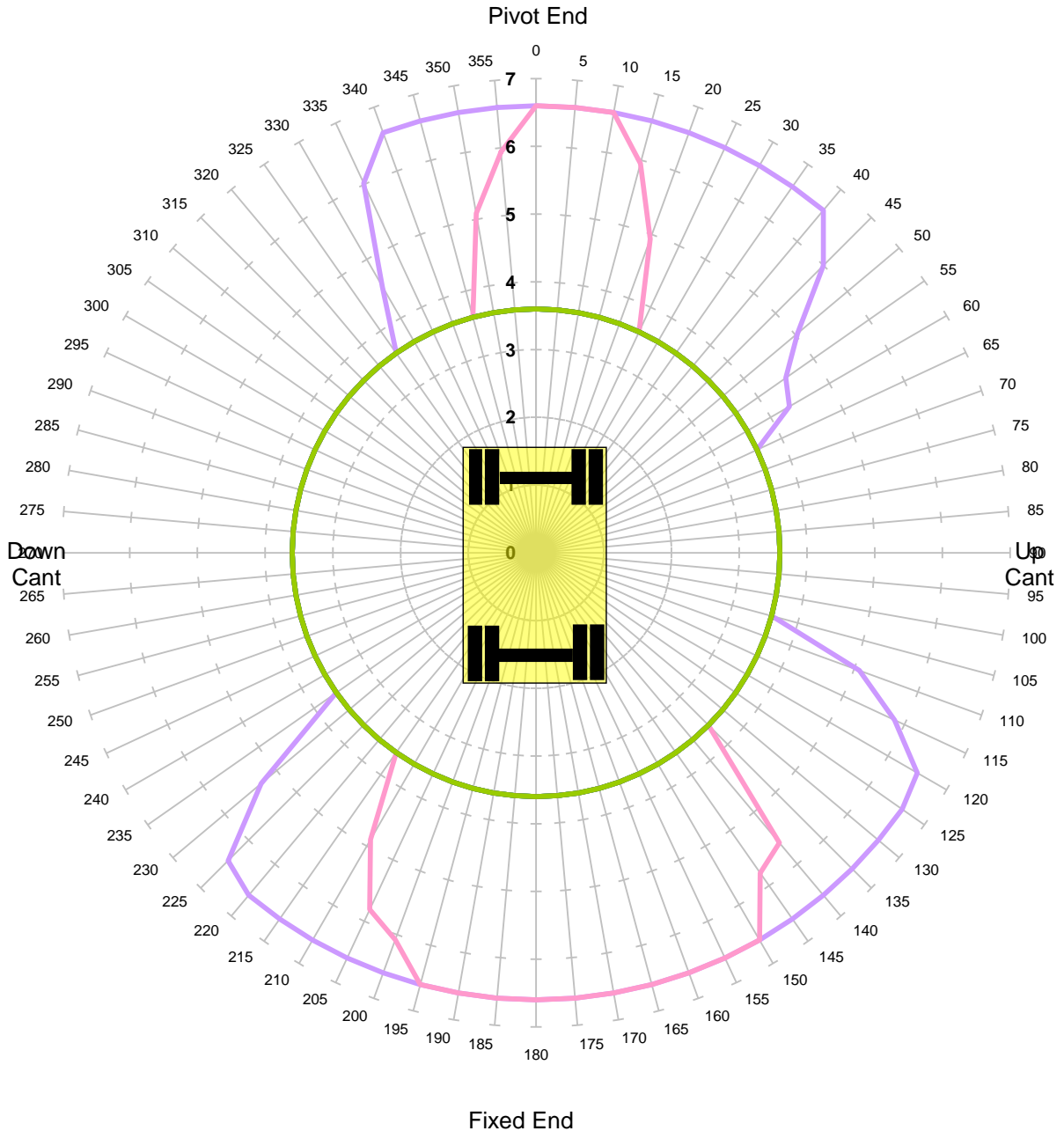

Units in Tonnes

- 1
- 2
- 3
- 4
- 5
- 6
- 7
- 8
- 9
- 10

| | | | |
|-----------------------------|--------------|-----------------------|----------------|
| MACHINE & MODEL: | Case 988 | REFERENCE: | 99709 940608-1 |
| SERIAL No: | CGG0232265 | DATE OF CHART: | 27-Jan-2022 |
| EQUIPMENT: | 4.29m + 2.1m | SAFETY FACTOR: | 44.0% |
| COMMENT: | | | |



KING TRANSPORT EQUIPMENT LTD
Max Capacity Contours of Radius(m) Plots 2.1m Dipper
Gradient 1 in -25 Height 2m Lift BP
Unlocked Rail Cant 150mm - Tandem Lift

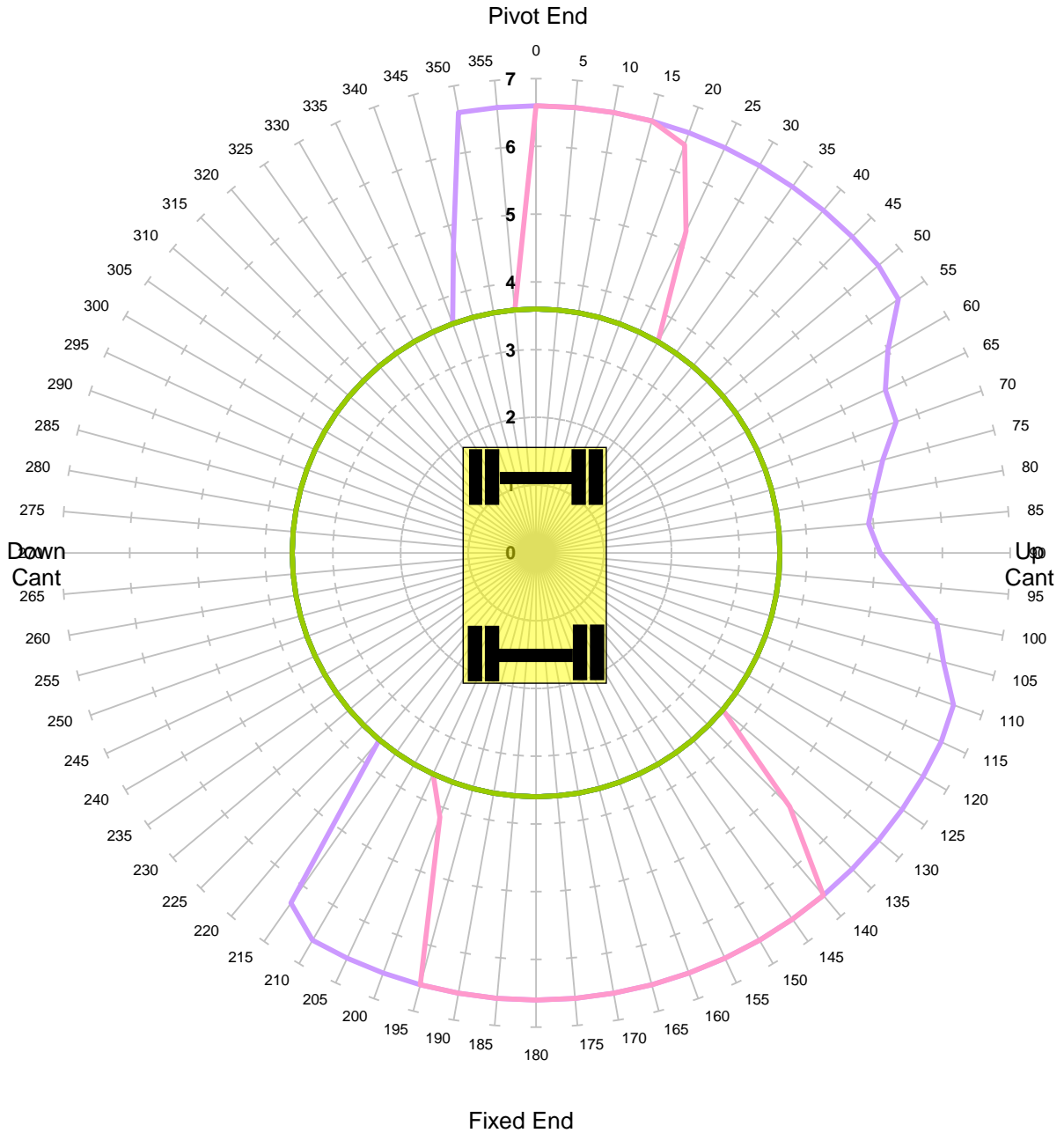

Units in Tonnes

- 1
- 2
- 3
- 4
- 5
- 6
- 7
- 8
- 9
- 10

| | | | |
|-----------------------------|--------------|-----------------------|----------------|
| MACHINE & MODEL: | Case 988 | REFERENCE: | 99709 940608-1 |
| SERIAL No: | CGG0232265 | DATE OF CHART: | 27-Jan-2022 |
| EQUIPMENT: | 4.29m + 2.1m | SAFETY FACTOR: | 44.0% |
| COMMENT: | | | |



KING TRANSPORT EQUIPMENT LTD
Max Capacity Contours of Radius(m) Plots 2.1m Dipper
Gradient 1 in -25 Height 2m Lift BP
Locked Rail Cant -150mm - Tandem Lift

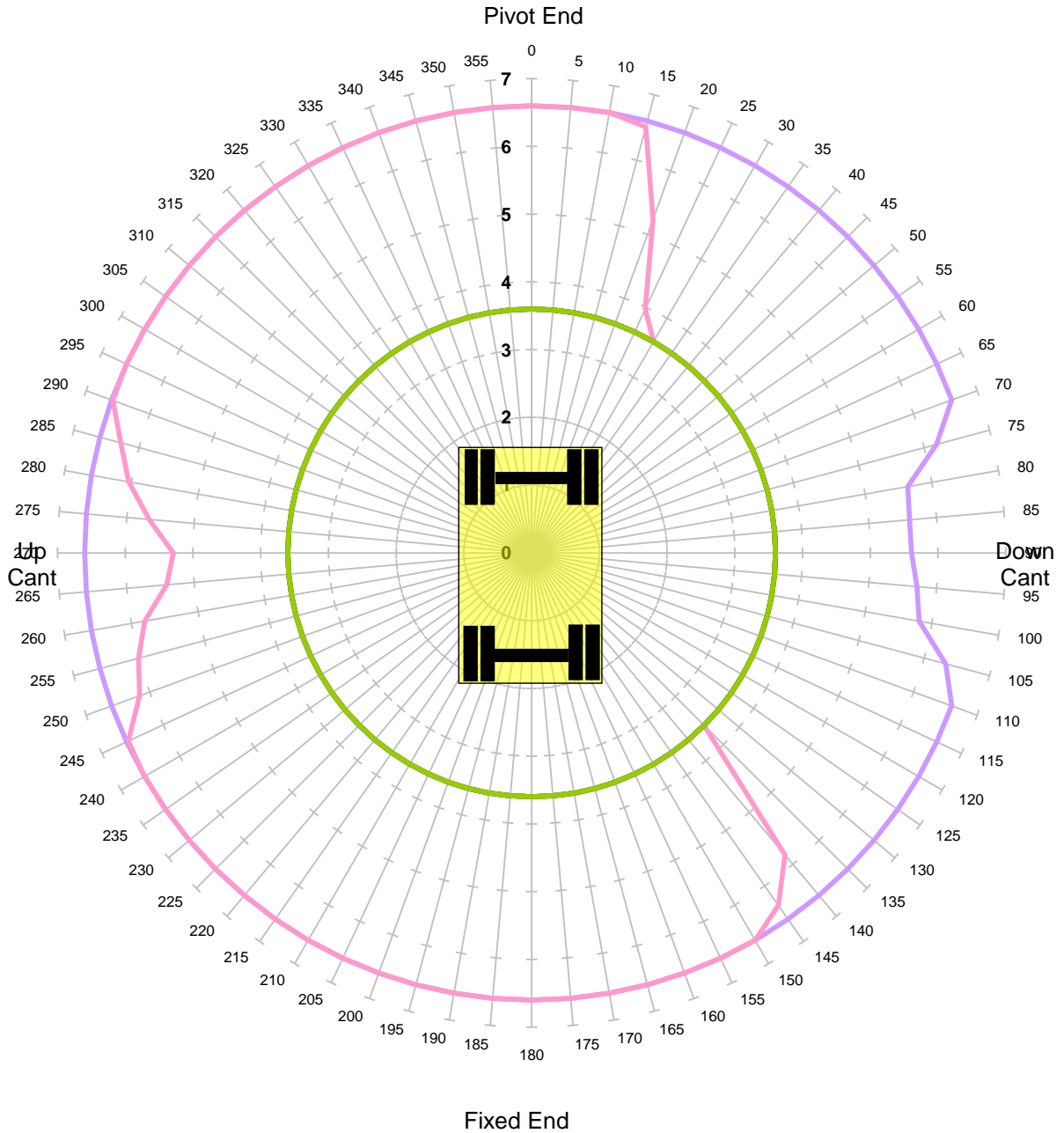

Units in Tonnes

- 1
- 2
- 3
- 4
- 5
- 6
- 7
- 8
- 9
- 10

| | | | |
|-----------------------------|--------------|-----------------------|----------------|
| MACHINE & MODEL: | Case 988 | REFERENCE: | 99709 940608-1 |
| SERIAL No: | CGG0232265 | DATE OF CHART: | 27-Jan-2022 |
| EQUIPMENT: | 4.29m + 2.1m | SAFETY FACTOR: | 59.0% |
| COMMENT: | | | |



KING TRANSPORT EQUIPMENT LTD

Max Capacity Contours of Radius(m) Plots 2.1m Dipper

Gradient 1 in -25 Height 2m Lift BP

Locked Rail Cant -50mm - Tandem Lift

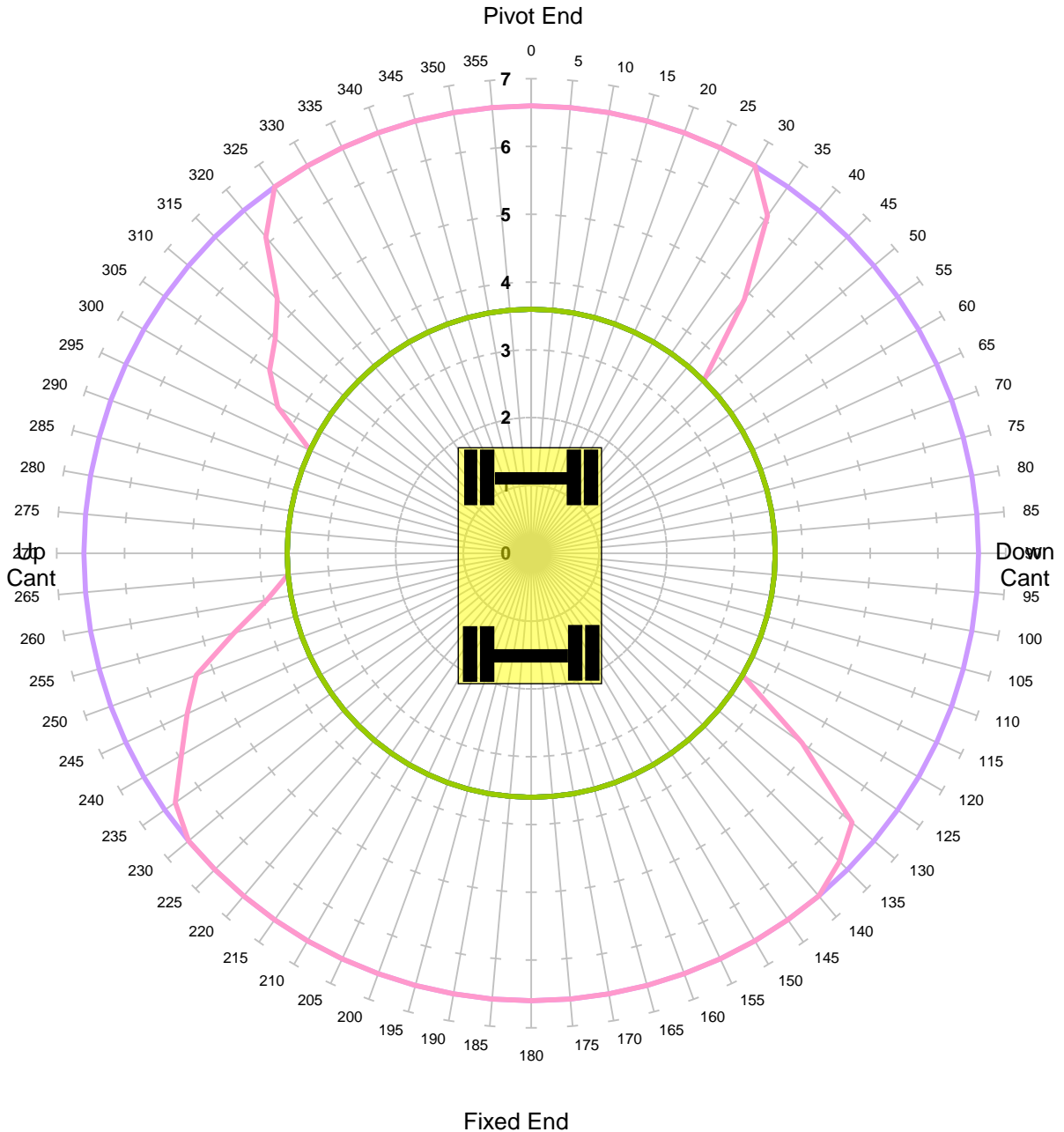

Units in Tonnes

- 1
- 2
- 3
- 4
- 5
- 6
- 7
- 8
- 9
- 10

| | | | |
|-----------------------------|--------------|-----------------------|----------------|
| MACHINE & MODEL: | Case 988 | REFERENCE: | 99709 940608-1 |
| SERIAL No: | CGG0232265 | DATE OF CHART: | 27-Jan-2022 |
| EQUIPMENT: | 4.29m + 2.1m | SAFETY FACTOR: | 59.0% |
| COMMENT: | | | |



KING TRANSPORT EQUIPMENT LTD
Max Capacity Contours of Radius(m) Plots 2.1m Dipper
Gradient 1 in -25 Height 2m Lift BP
Locked Rail Cant 50mm - Tandem Lift

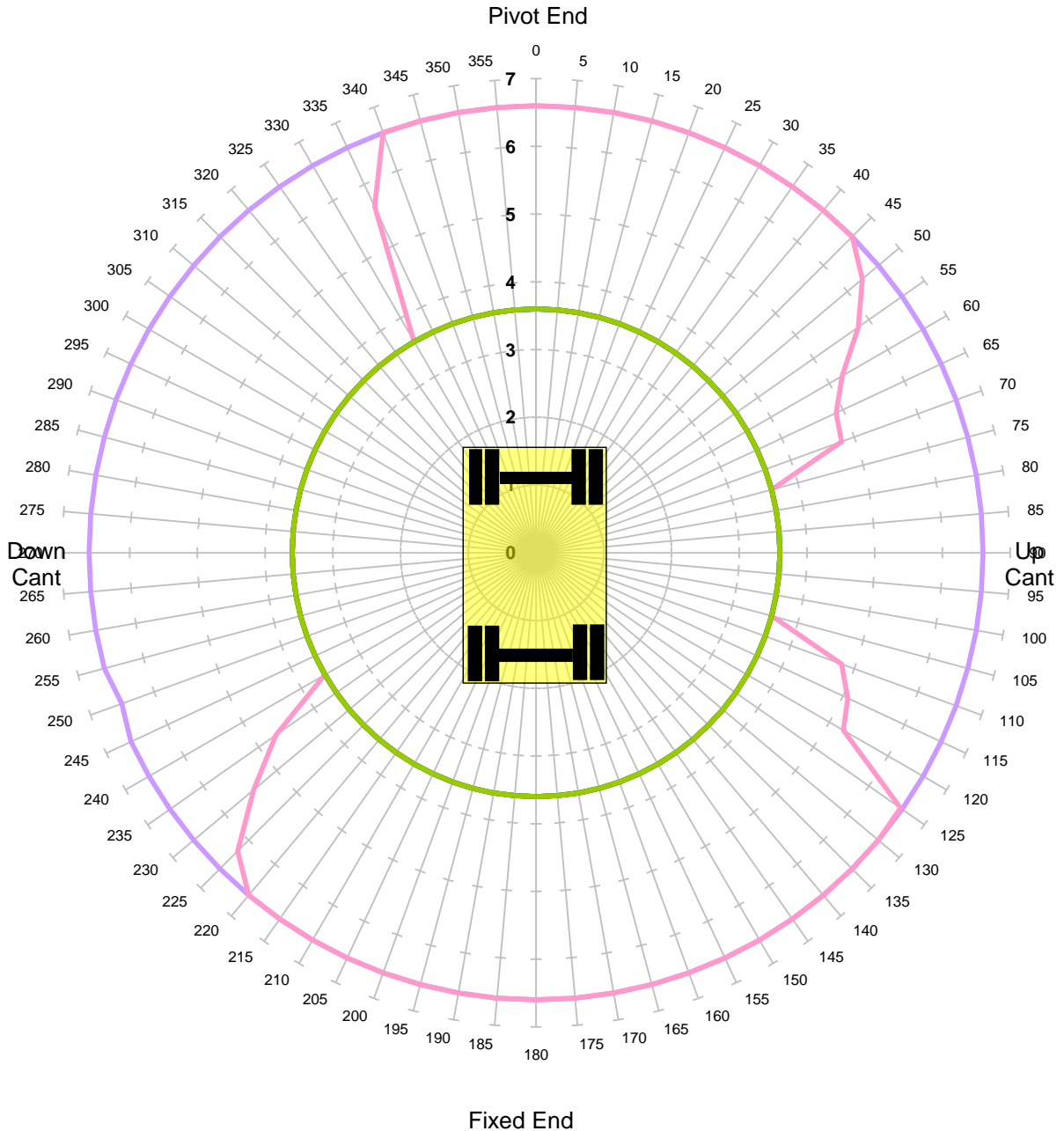

Units in Tonnes

- 1
- 2
- 3
- 4
- 5
- 6
- 7
- 8
- 9
- 10

| | | | |
|-----------------------------|--------------|-----------------------|----------------|
| MACHINE & MODEL: | Case 988 | REFERENCE: | 99709 940608-1 |
| SERIAL No: | CGG0232265 | DATE OF CHART: | 27-Jan-2022 |
| EQUIPMENT: | 4.29m + 2.1m | SAFETY FACTOR: | 59.0% |
| COMMENT: | | | |



KING TRANSPORT EQUIPMENT LTD
Max Capacity Contours of Radius(m) Plots 2.1m Dipper
Gradient 1 in -25 Height 2m Lift BP
Locked Rail Cant 150mm - Tandem Lift

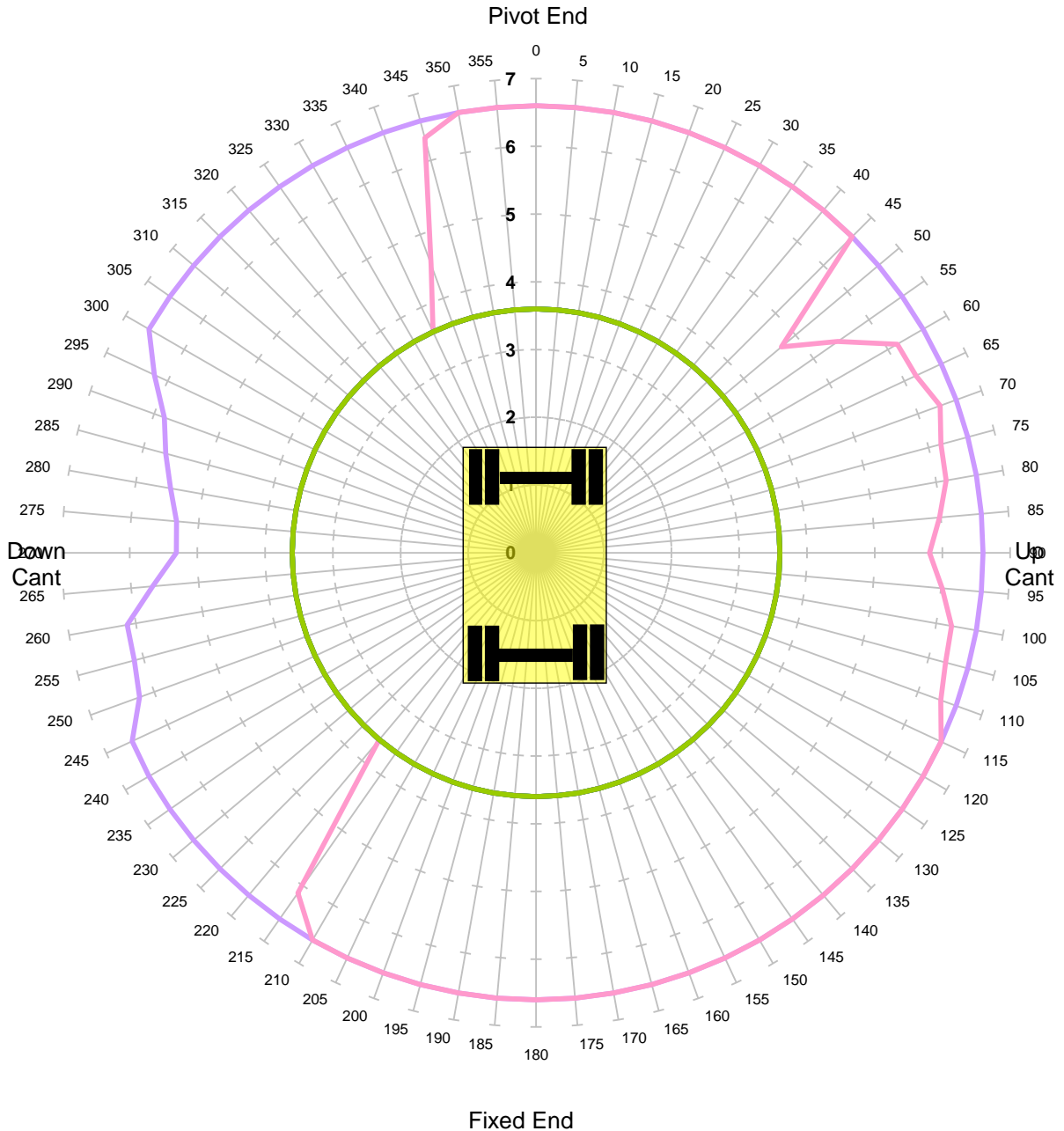

Units in Tonnes

- 1
- 2
- 3
- 4
- 5
- 6
- 7
- 8
- 9
- 10

| | | | |
|-----------------------------|--------------|-----------------------|----------------|
| MACHINE & MODEL: | Case 988 | REFERENCE: | 99709 940608-1 |
| SERIAL No: | CGG0232265 | DATE OF CHART: | 27-Jan-2022 |
| EQUIPMENT: | 4.29m + 2.1m | SAFETY FACTOR: | 59.0% |
| COMMENT: | | | |



KING TRANSPORT EQUIPMENT LTD
Max Capacity Contours of Radius(m) Plots 2.1m Dipper
Level Ground Height 2m Lift BP
Unlocked Road - Tandem Lift

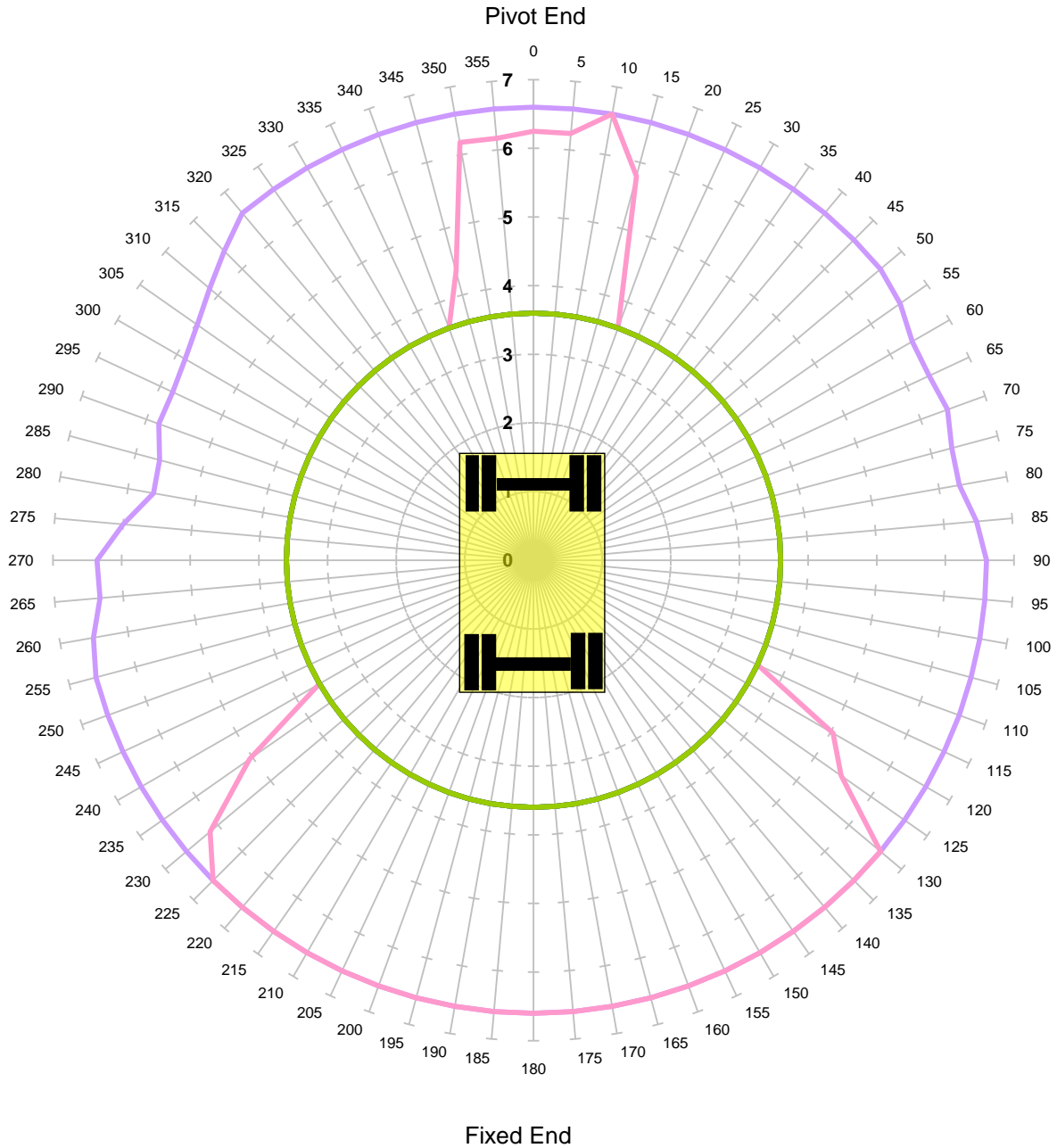

Units in Tonnes

- 1
- 2
- 3
- 4
- 5
- 6
- 7
- 8
- 9
- 10

| | | | |
|-----------------------------|--------------|-----------------------|----------------|
| MACHINE & MODEL: | Case 988 | REFERENCE: | 99709 940608-1 |
| SERIAL No: | CGG0232265 | DATE OF CHART: | 27-Jan-2022 |
| EQUIPMENT: | 4.29m + 2.1m | SAFETY FACTOR: | 50.0% |
| COMMENT: | | | |



KING TRANSPORT EQUIPMENT LTD
Max Capacity Contours of Radius(m) Plots 2.1m Dipper
Level Ground Height 2m Lift BP
Locked Road - Tandem Lift

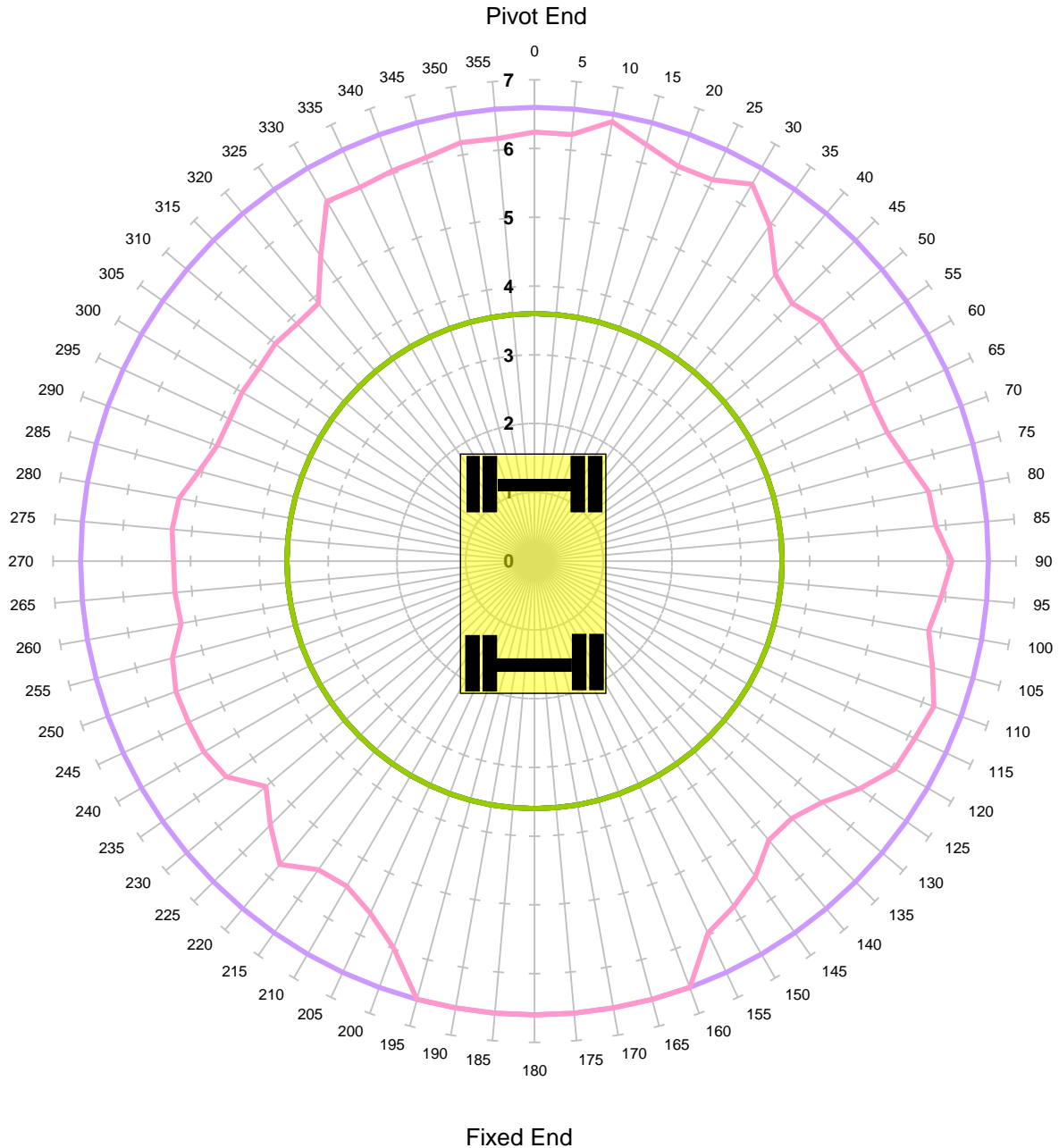

Units in Tonnes

- 1
- 2
- 3
- 4
- 5
- 6
- 7
- 8
- 9
- 10

| | | | |
|-----------------------------|--------------|-----------------------|----------------|
| MACHINE & MODEL: | Case 988 | REFERENCE: | 99709 940608-1 |
| SERIAL No: | CGG0232265 | DATE OF CHART: | 27-Jan-2022 |
| EQUIPMENT: | 4.29m + 2.1m | SAFETY FACTOR: | 50.0% |
| COMMENT: | | | |



KING TRANSPORT EQUIPMENT LTD
Max Capacity Contours of Radius(m) Plots 2.1m Dipper
Gradient 1 in -25 Height 2m Lift ALP1
Unlocked Rail Cant -150mm

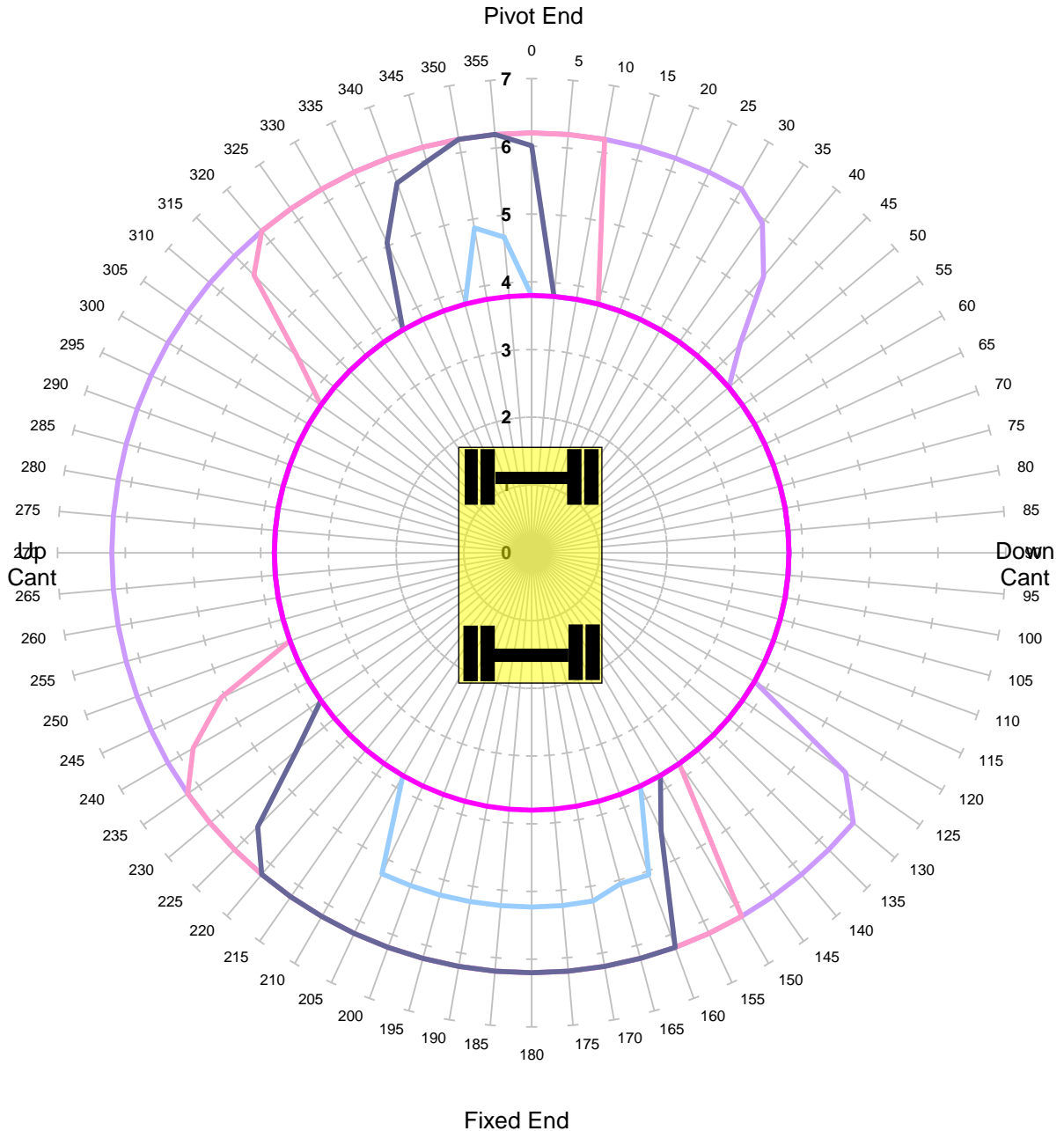

Units in Tonnes

- 1
- 2
- 3
- 4
- 5

| | | | |
|-----------------------------|--------------|-----------------------|----------------|
| MACHINE & MODEL: | Case 988 | REFERENCE: | 99709 940608-1 |
| SERIAL No: | CGG0232265 | DATE OF CHART: | 27-Jan-2022 |
| EQUIPMENT: | 4.29m + 2.1m | SAFETY FACTOR: | 67.0% |
| COMMENT: | | | |



KING TRANSPORT EQUIPMENT LTD
Max Capacity Contours of Radius(m) Plots 2.1m Dipper
Gradient 1 in -25 Height 2m Lift ALP1
Unlocked Rail Cant -50mm

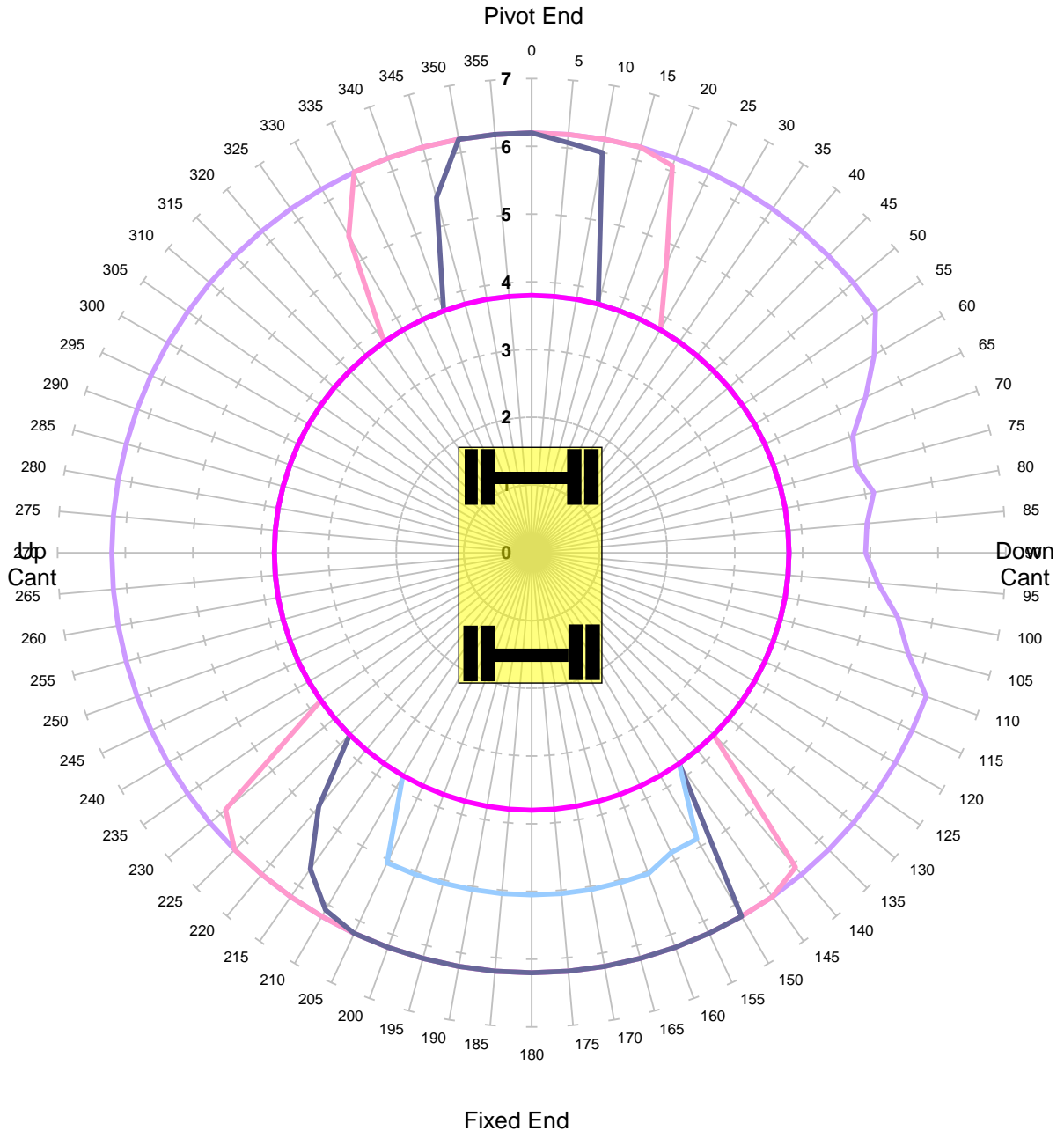

Units in Tonnes

- 1
- 2
- 3
- 4
- 5

| | | | |
|-----------------------------|--------------|-----------------------|----------------|
| MACHINE & MODEL: | Case 988 | REFERENCE: | 99709 940608-1 |
| SERIAL No: | CGG0232265 | DATE OF CHART: | 27-Jan-2022 |
| EQUIPMENT: | 4.29m + 2.1m | SAFETY FACTOR: | 67.0% |
| COMMENT: | | | |



KING TRANSPORT EQUIPMENT LTD
Max Capacity Contours of Radius(m) Plots 2.1m Dipper
Gradient 1 in -25 Height 2m Lift ALP1
Unlocked Rail Cant 50mm

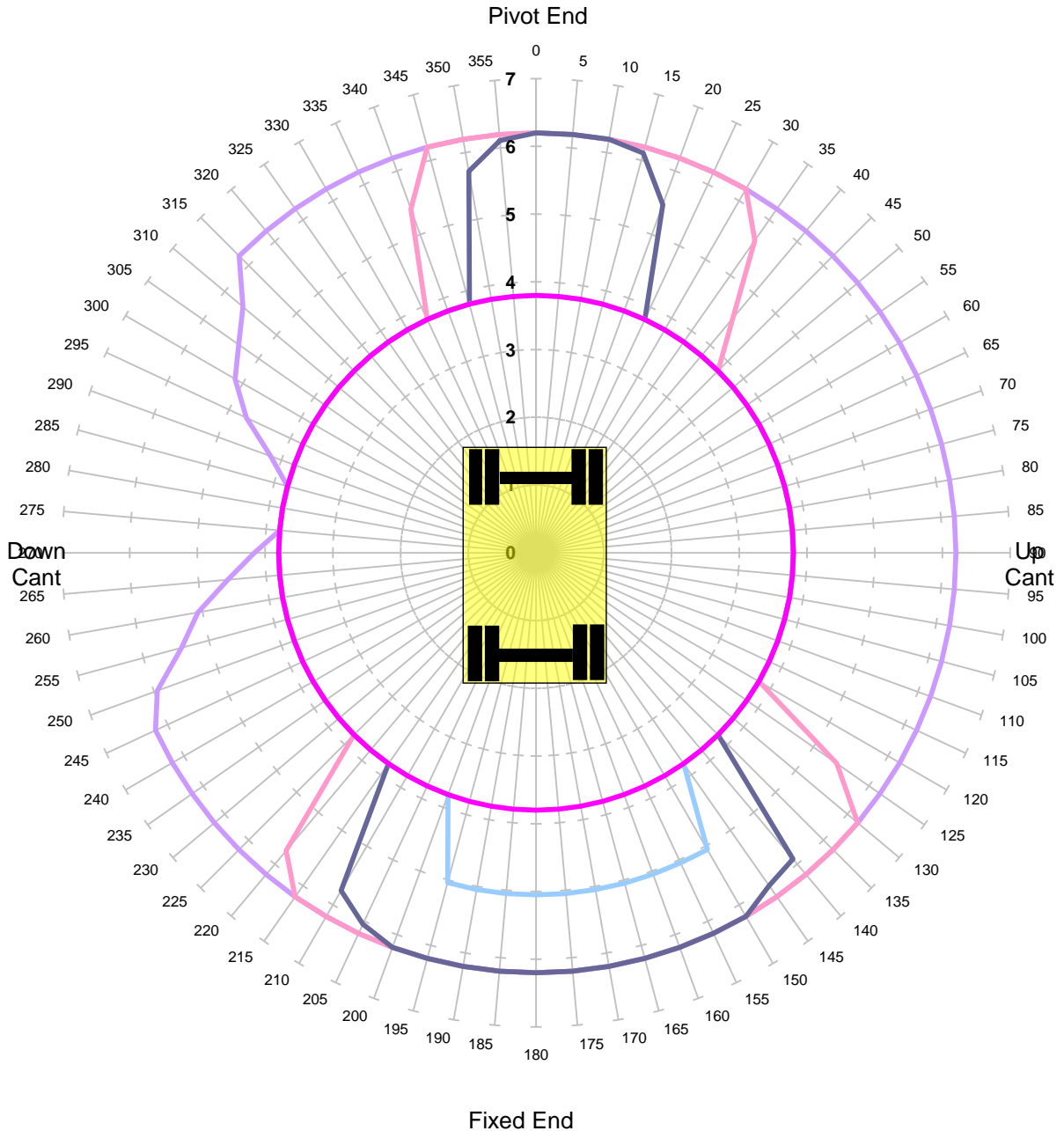

Units in Tonnes

- 1
- 2
- 3
- 4
- 5

| | | | |
|-----------------------------|--------------|-----------------------|----------------|
| MACHINE & MODEL: | Case 988 | REFERENCE: | 99709 940608-1 |
| SERIAL No: | CGG0232265 | DATE OF CHART: | 27-Jan-2022 |
| EQUIPMENT: | 4.29m + 2.1m | SAFETY FACTOR: | 67.0% |
| COMMENT: | | | |



KING TRANSPORT EQUIPMENT LTD
Max Capacity Contours of Radius(m) Plots 2.1m Dipper
Gradient 1 in -25 Height 2m Lift ALP1
Unlocked Rail Cant 150mm

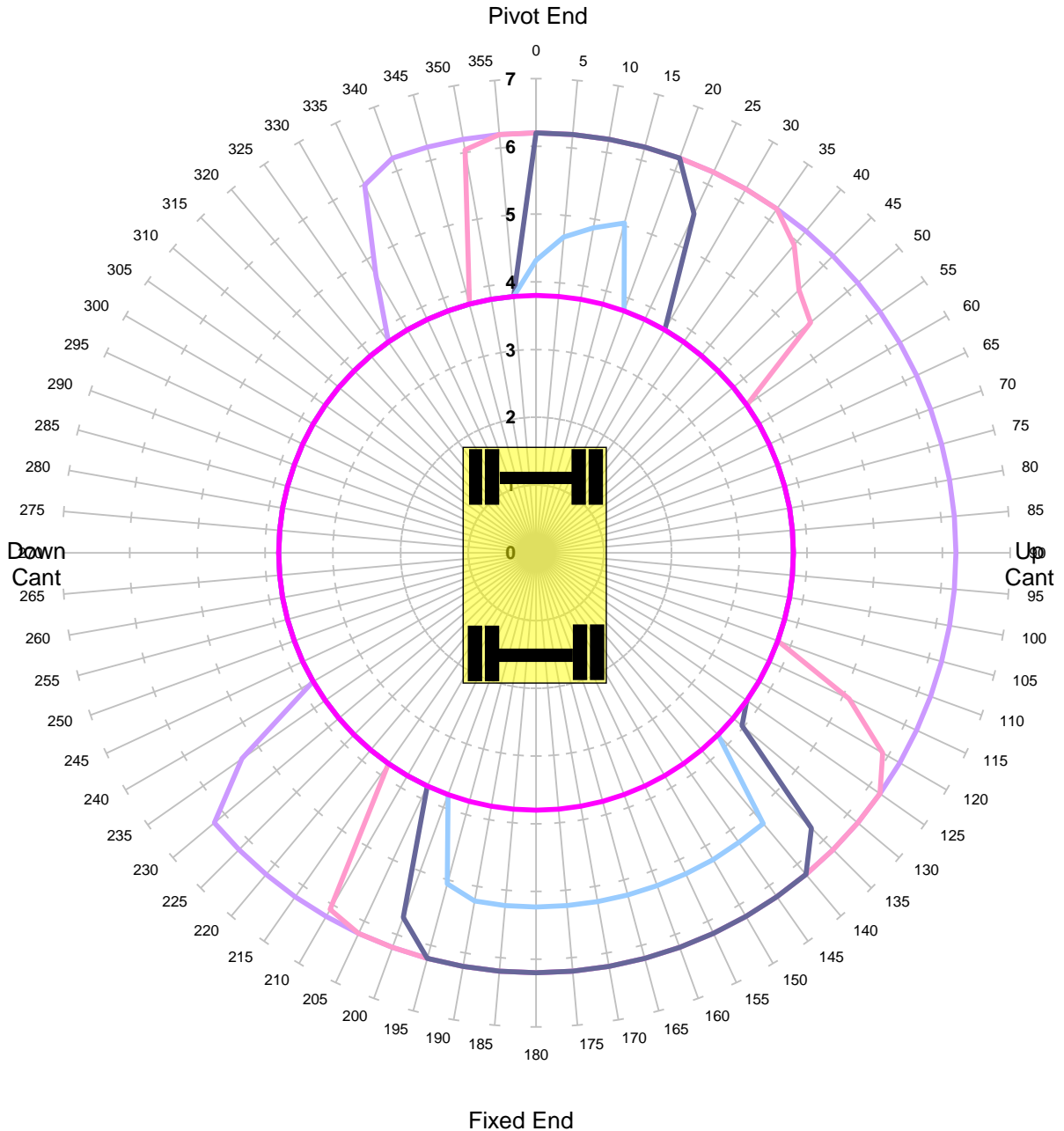

Units in Tonnes

- 1
- 2
- 3
- 4
- 5

| | | | |
|-----------------------------|--------------|-----------------------|----------------|
| MACHINE & MODEL: | Case 988 | REFERENCE: | 99709 940608-1 |
| SERIAL No: | CGG0232265 | DATE OF CHART: | 27-Jan-2022 |
| EQUIPMENT: | 4.29m + 2.1m | SAFETY FACTOR: | 67.0% |
| COMMENT: | | | |



KING TRANSPORT EQUIPMENT LTD
Max Capacity Contours of Radius(m) Plots 2.1m Dipper
Gradient 1 in -25 Height 2m Lift ALP1
Locked Rail Cant -150mm

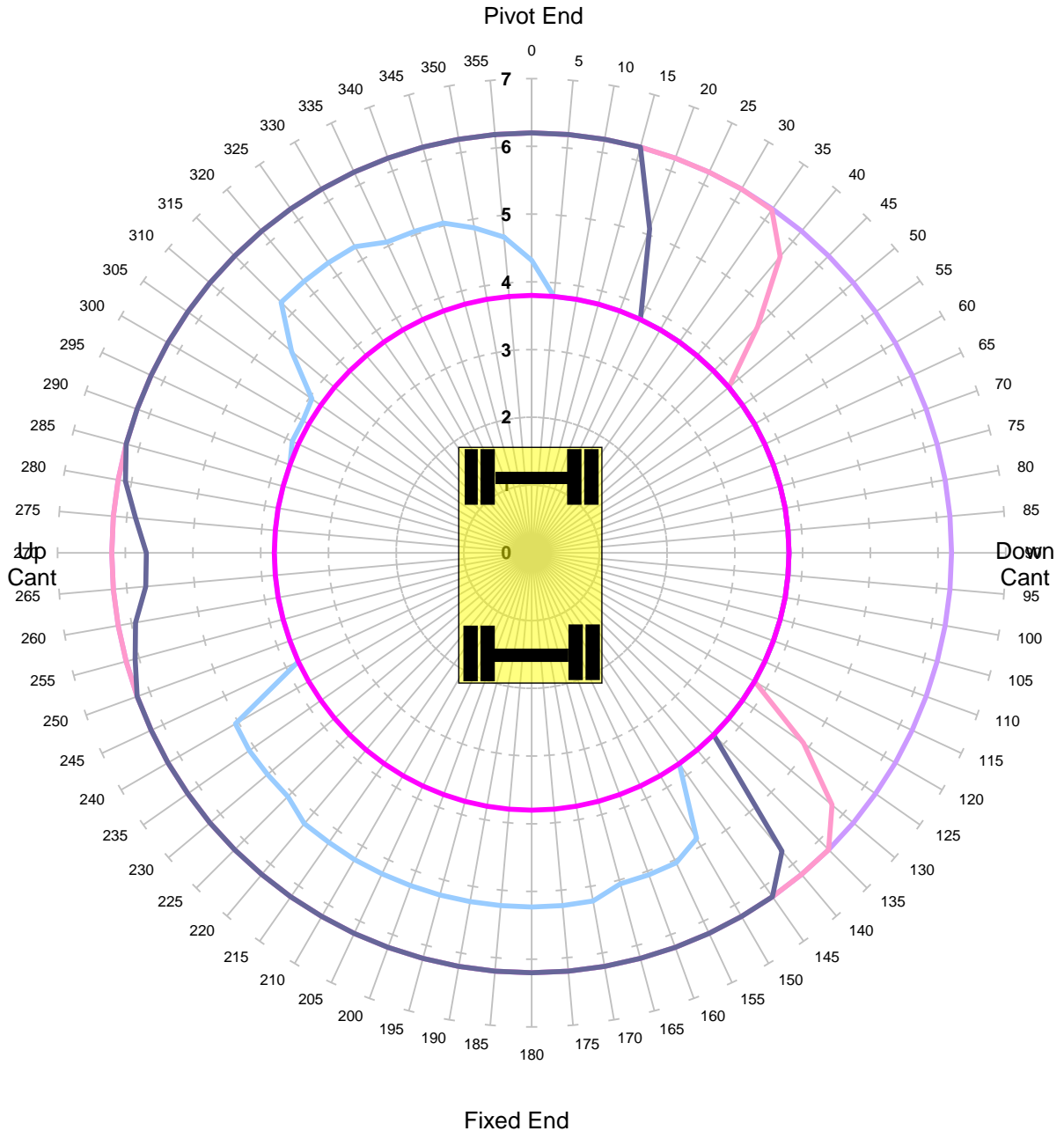

Units in Tonnes

- 1
- 2
- 3
- 4
- 5

| | | | |
|-----------------------------|--------------|-----------------------|----------------|
| MACHINE & MODEL: | Case 988 | REFERENCE: | 99709 940608-1 |
| SERIAL No: | CGG0232265 | DATE OF CHART: | 27-Jan-2022 |
| EQUIPMENT: | 4.29m + 2.1m | SAFETY FACTOR: | 90.0% |
| COMMENT: | | | |



KING TRANSPORT EQUIPMENT LTD
Max Capacity Contours of Radius(m) Plots 2.1m Dipper
Gradient 1 in -25 Height 2m Lift ALP1
Locked Rail Cant -50mm

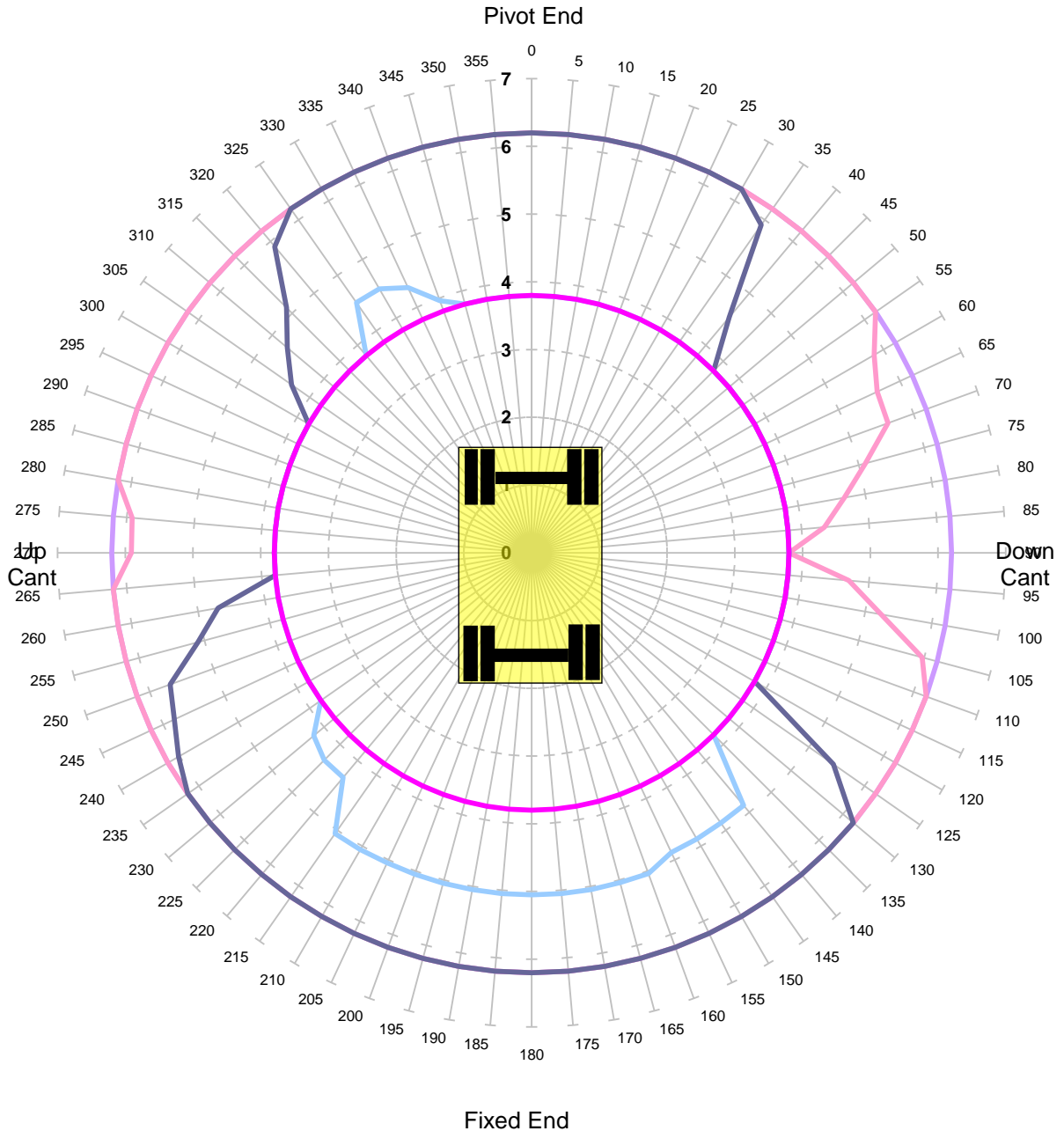

Units in Tonnes

- 1
- 2
- 3
- 4
- 5

| | | | |
|-----------------------------|--------------|-----------------------|----------------|
| MACHINE & MODEL: | Case 988 | REFERENCE: | 99709 940608-1 |
| SERIAL No: | CGG0232265 | DATE OF CHART: | 27-Jan-2022 |
| EQUIPMENT: | 4.29m + 2.1m | SAFETY FACTOR: | 90.0% |
| COMMENT: | | | |



KING TRANSPORT EQUIPMENT LTD
Max Capacity Contours of Radius(m) Plots 2.1m Dipper
Gradient 1 in -25 Height 2m Lift ALP1
Locked Rail Cant 50mm

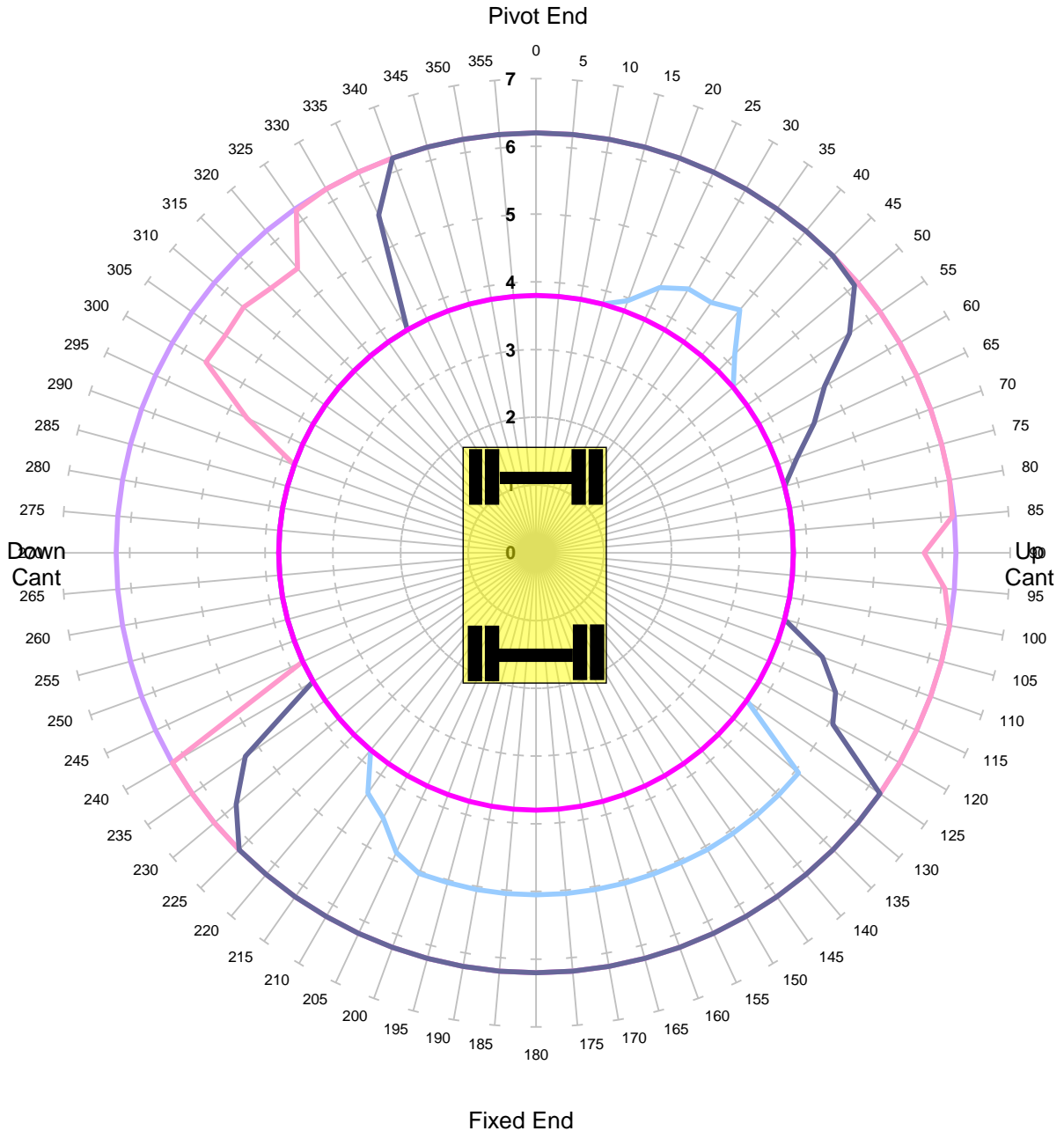

Units in Tonnes

- 1
- 2
- 3
- 4
- 5

| | | | |
|-----------------------------|--------------|-----------------------|----------------|
| MACHINE & MODEL: | Case 988 | REFERENCE: | 99709 940608-1 |
| SERIAL No: | CGG0232265 | DATE OF CHART: | 27-Jan-2022 |
| EQUIPMENT: | 4.29m + 2.1m | SAFETY FACTOR: | 90.0% |
| COMMENT: | | | |



KING TRANSPORT EQUIPMENT LTD
Max Capacity Contours of Radius(m) Plots 2.1m Dipper
Gradient 1 in -25 Height 2m Lift ALP1
Locked Rail Cant 150mm

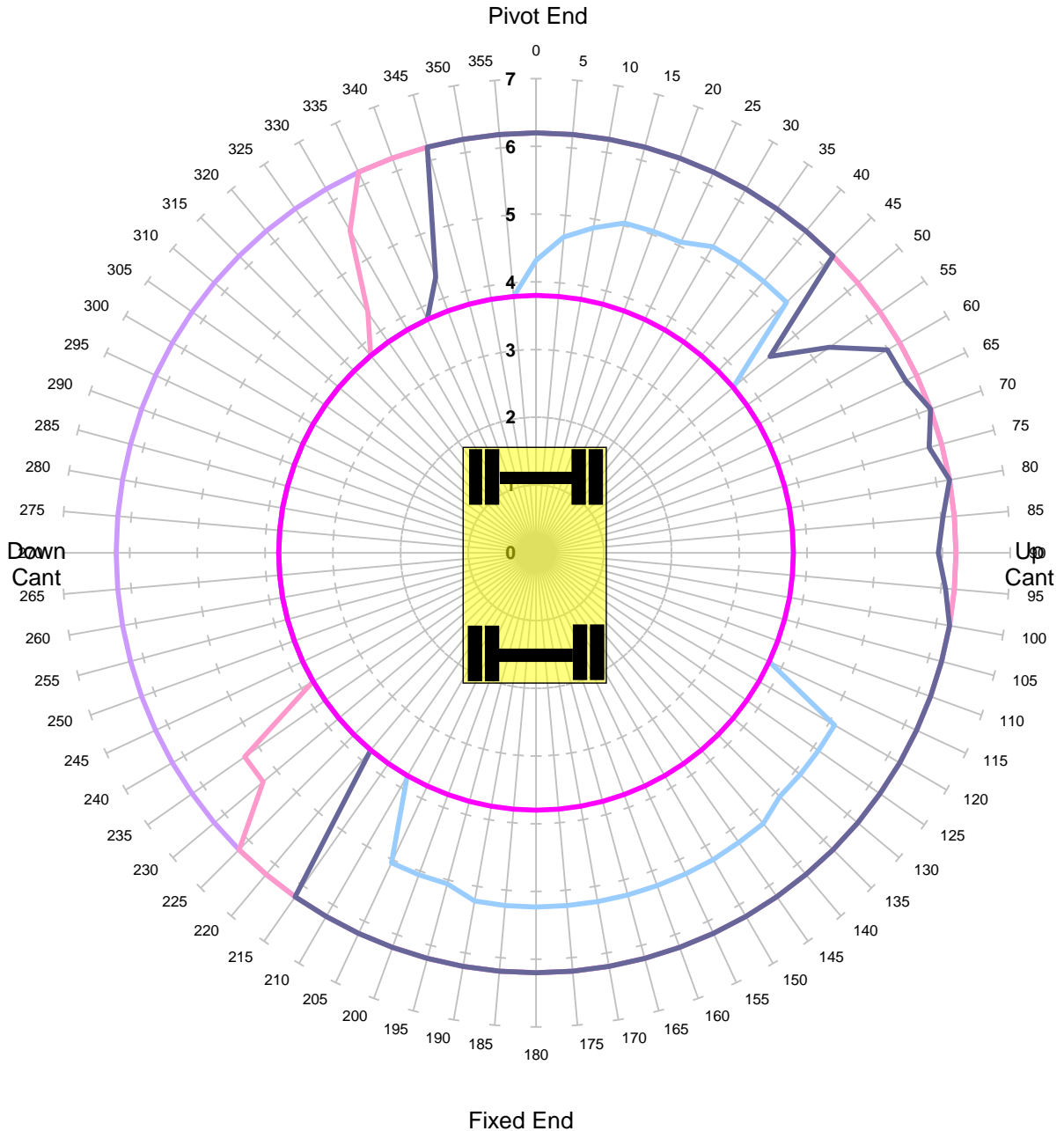

Units in Tonnes

- 1
- 2
- 3
- 4
- 5

| | | | |
|-----------------------------|--------------|-----------------------|----------------|
| MACHINE & MODEL: | Case 988 | REFERENCE: | 99709 940608-1 |
| SERIAL No: | CGG0232265 | DATE OF CHART: | 27-Jan-2022 |
| EQUIPMENT: | 4.29m + 2.1m | SAFETY FACTOR: | 90.0% |
| COMMENT: | | | |



KING TRANSPORT EQUIPMENT LTD
Max Capacity Contours of Radius(m) Plots 2.1m Dipper
Level Ground Height 2m Lift ALP1
Unlocked Road

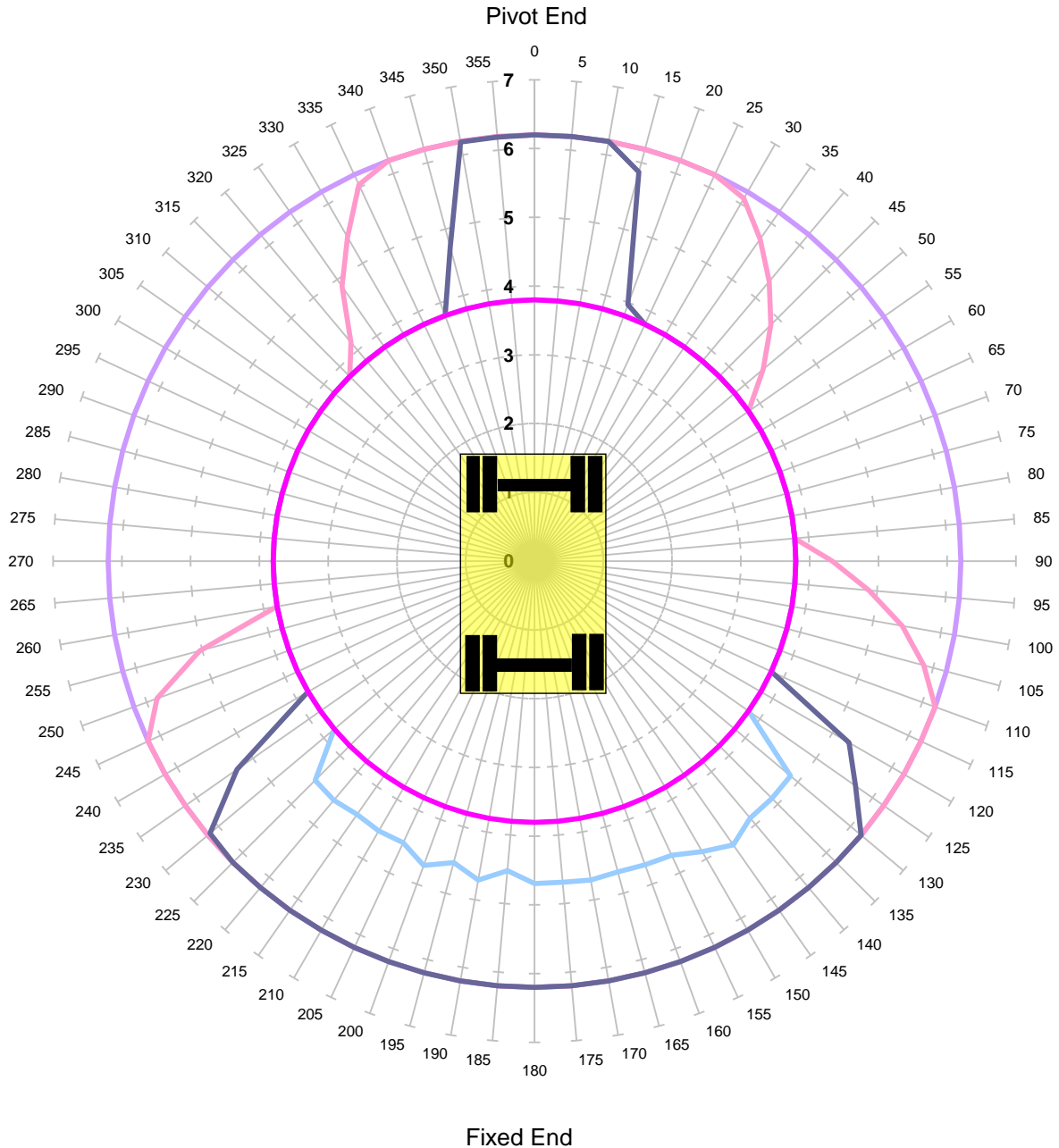

Units in Tonnes

- 1
- 2
- 3
- 4
- 5

| | | | |
|-----------------------------|--------------|-----------------------|----------------|
| MACHINE & MODEL: | Case 988 | REFERENCE: | 99709 940608-1 |
| SERIAL No: | CGG0232265 | DATE OF CHART: | 27-Jan-2022 |
| EQUIPMENT: | 4.29m + 2.1m | SAFETY FACTOR: | 75.0% |
| COMMENT: | | | |



KING TRANSPORT EQUIPMENT LTD
Max Capacity Contours of Radius(m) Plots 2.1m Dipper
Level Ground Height 2m Lift ALP1
Locked Road

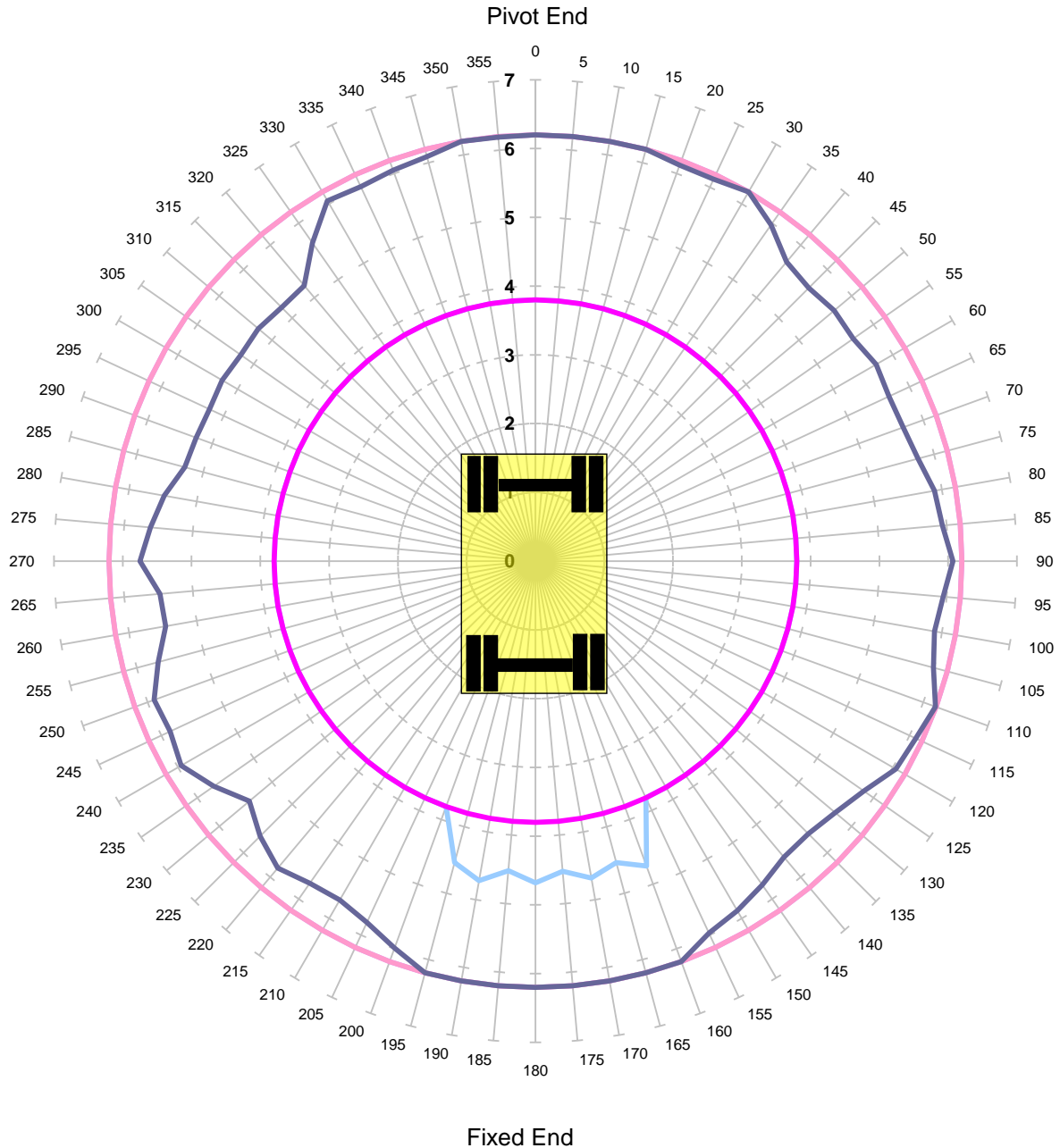

Units in Tonnes

- 1
- 2
- 3
- 4
- 5

| | | | |
|-----------------------------|--------------|-----------------------|----------------|
| MACHINE & MODEL: | Case 988 | REFERENCE: | 99709 940608-1 |
| SERIAL No: | CGG0232265 | DATE OF CHART: | 27-Jan-2022 |
| EQUIPMENT: | 4.29m + 2.1m | SAFETY FACTOR: | 75.0% |
| COMMENT: | | | |



KING TRANSPORT EQUIPMENT LTD
Max Capacity Contours of Radius(m) Plots 2.1m Dipper
Gradient 1 in -25 Height 2m Lift ALP1
Unlocked Rail Cant -150mm - Tandem Lift

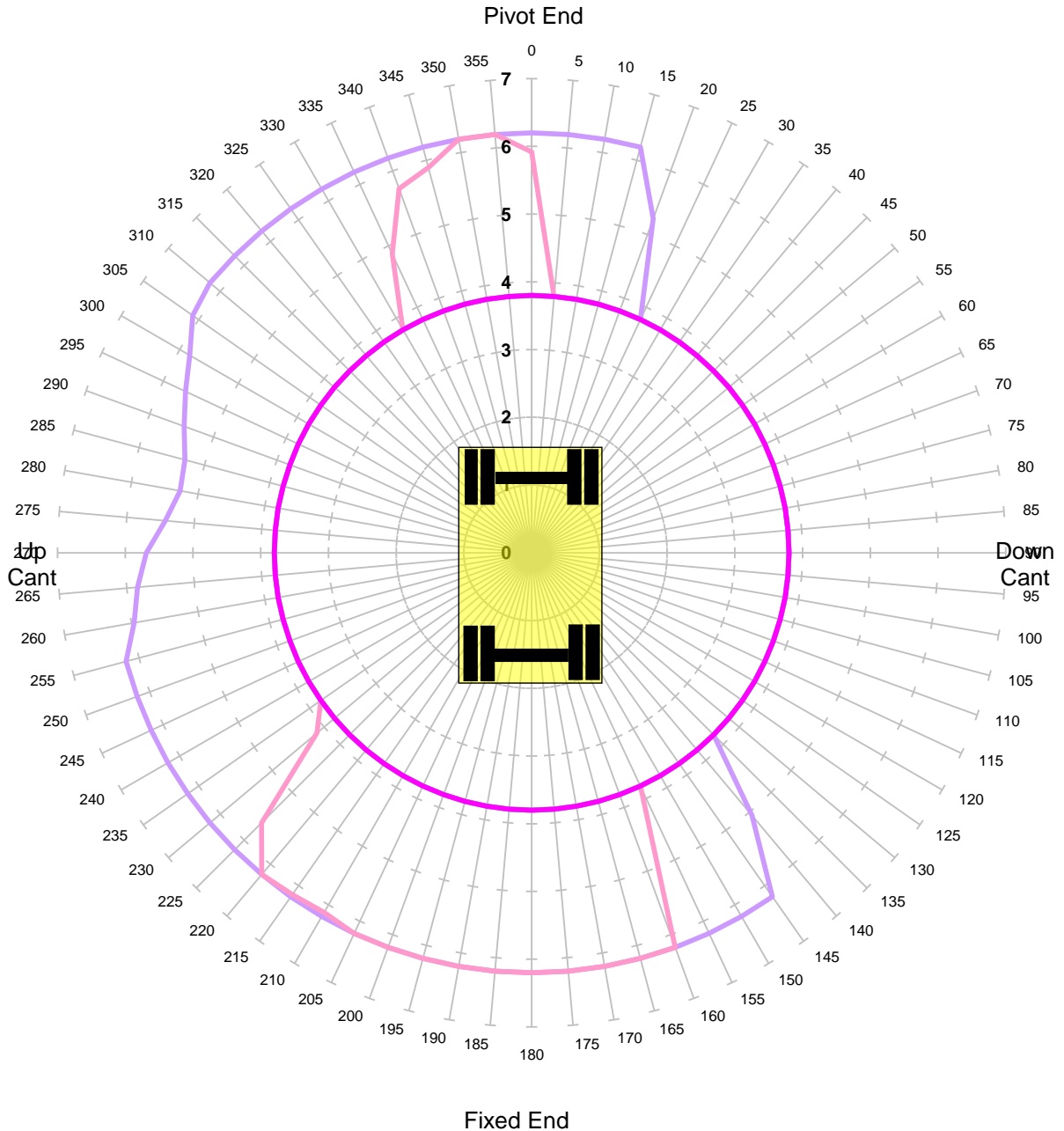

Units in Tonnes

- 1
- 2
- 3
- 4
- 5

| | | | |
|-----------------------------|--------------|-----------------------|----------------|
| MACHINE & MODEL: | Case 988 | REFERENCE: | 99709 940608-1 |
| SERIAL No: | CGG0232265 | DATE OF CHART: | 27-Jan-2022 |
| EQUIPMENT: | 4.29m + 2.1m | SAFETY FACTOR: | 44.0% |
| COMMENT: | | | |



KING TRANSPORT EQUIPMENT LTD
Max Capacity Contours of Radius(m) Plots 2.1m Dipper
Gradient 1 in -25 Height 2m Lift ALP1
Unlocked Rail Cant -50mm - Tandem Lift

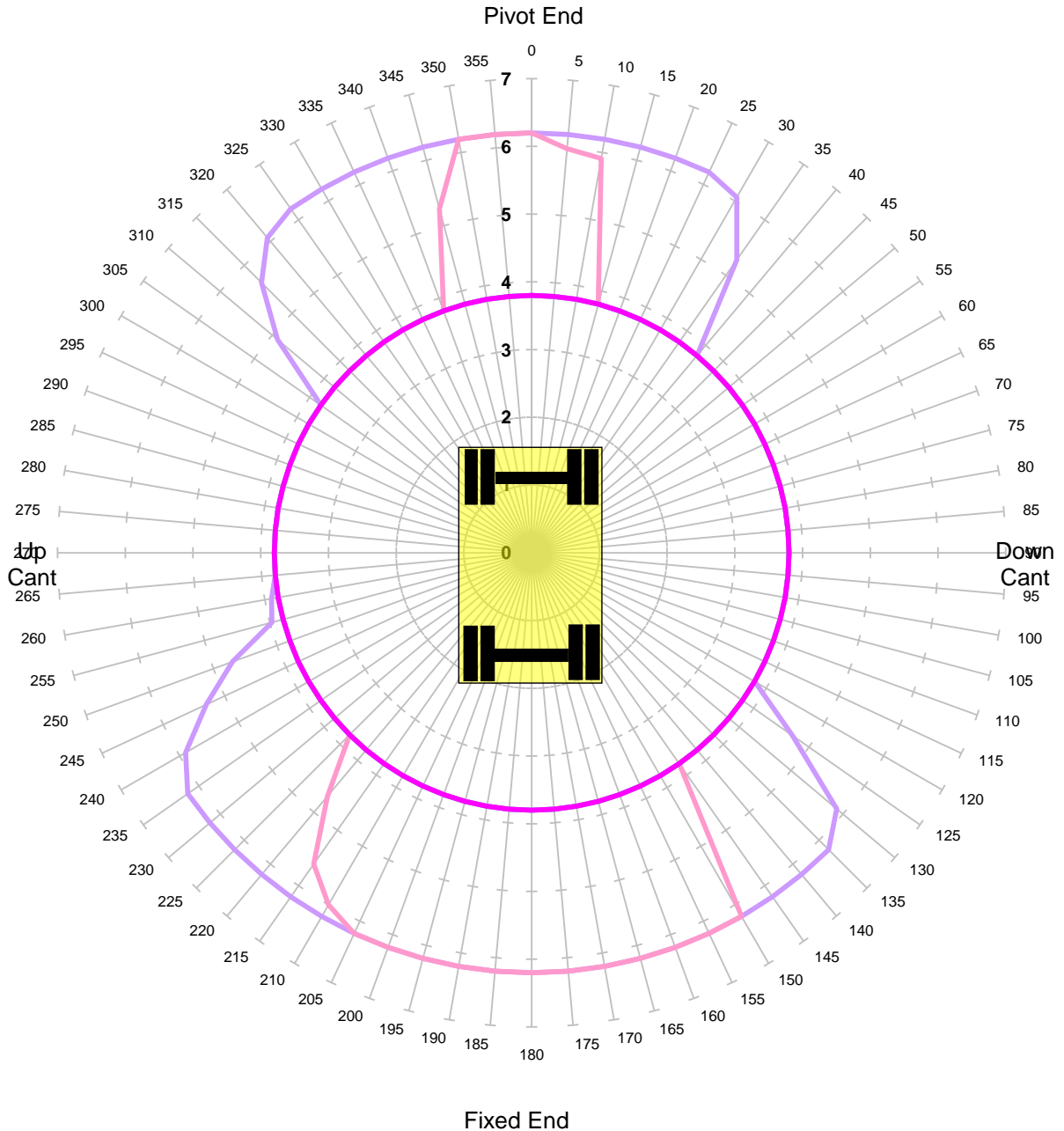

Units in Tonnes

- 1
- 2
- 3
- 4
- 5

| | | | |
|-----------------------------|--------------|-----------------------|----------------|
| MACHINE & MODEL: | Case 988 | REFERENCE: | 99709 940608-1 |
| SERIAL No: | CGG0232265 | DATE OF CHART: | 27-Jan-2022 |
| EQUIPMENT: | 4.29m + 2.1m | SAFETY FACTOR: | 44.0% |
| COMMENT: | | | |



KING TRANSPORT EQUIPMENT LTD
Max Capacity Contours of Radius(m) Plots 2.1m Dipper
Gradient 1 in -25 Height 2m Lift ALP1
Unlocked Rail Cant 50mm - Tandem Lift

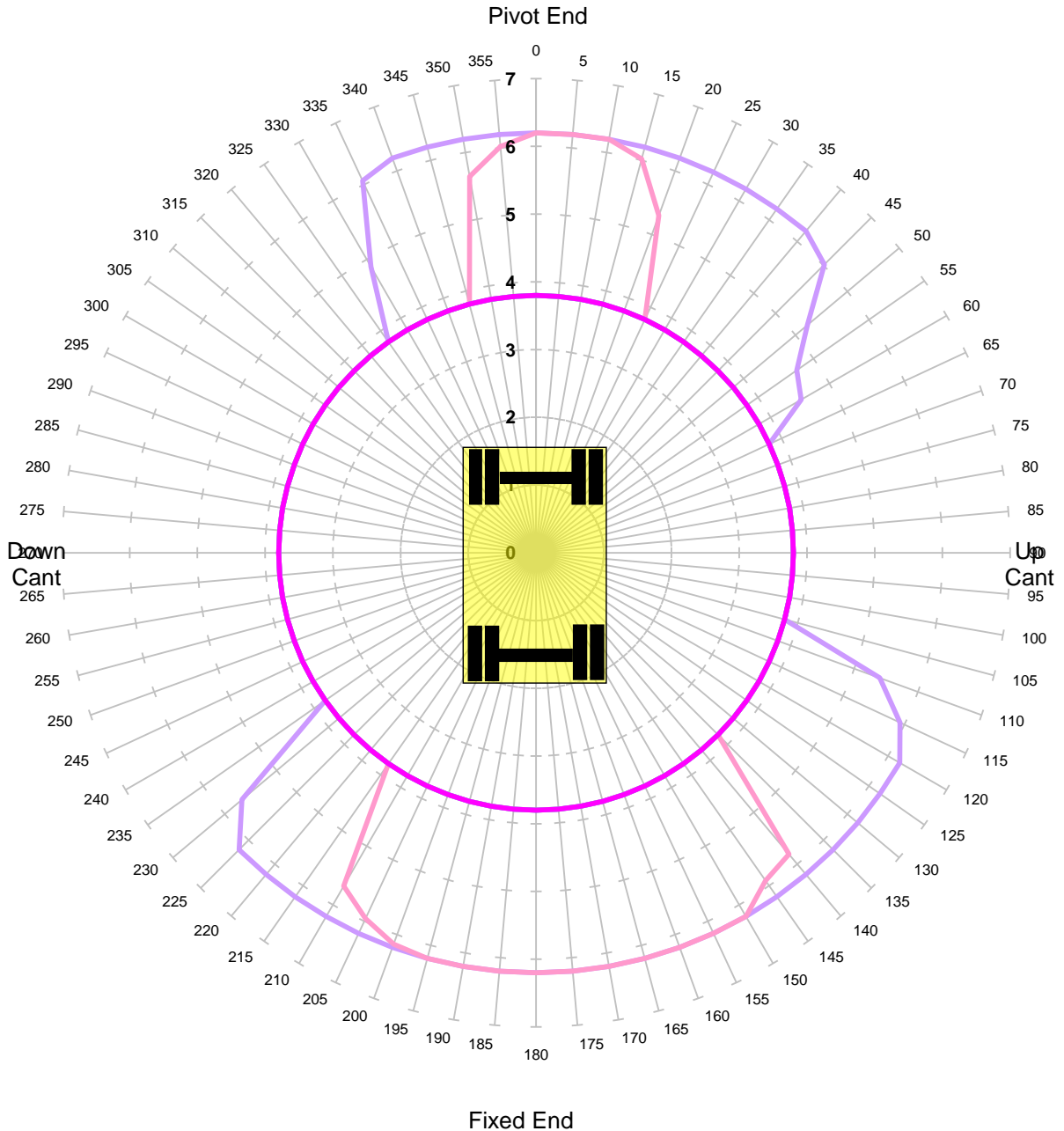

Units in Tonnes

- 1
- 2
- 3
- 4
- 5

| | | | |
|-----------------------------|--------------|-----------------------|----------------|
| MACHINE & MODEL: | Case 988 | REFERENCE: | 99709 940608-1 |
| SERIAL No: | CGG0232265 | DATE OF CHART: | 27-Jan-2022 |
| EQUIPMENT: | 4.29m + 2.1m | SAFETY FACTOR: | 44.0% |
| COMMENT: | | | |



KING TRANSPORT EQUIPMENT LTD
Max Capacity Contours of Radius(m) Plots 2.1m Dipper
Gradient 1 in -25 Height 2m Lift ALP1
Unlocked Rail Cant 150mm - Tandem Lift

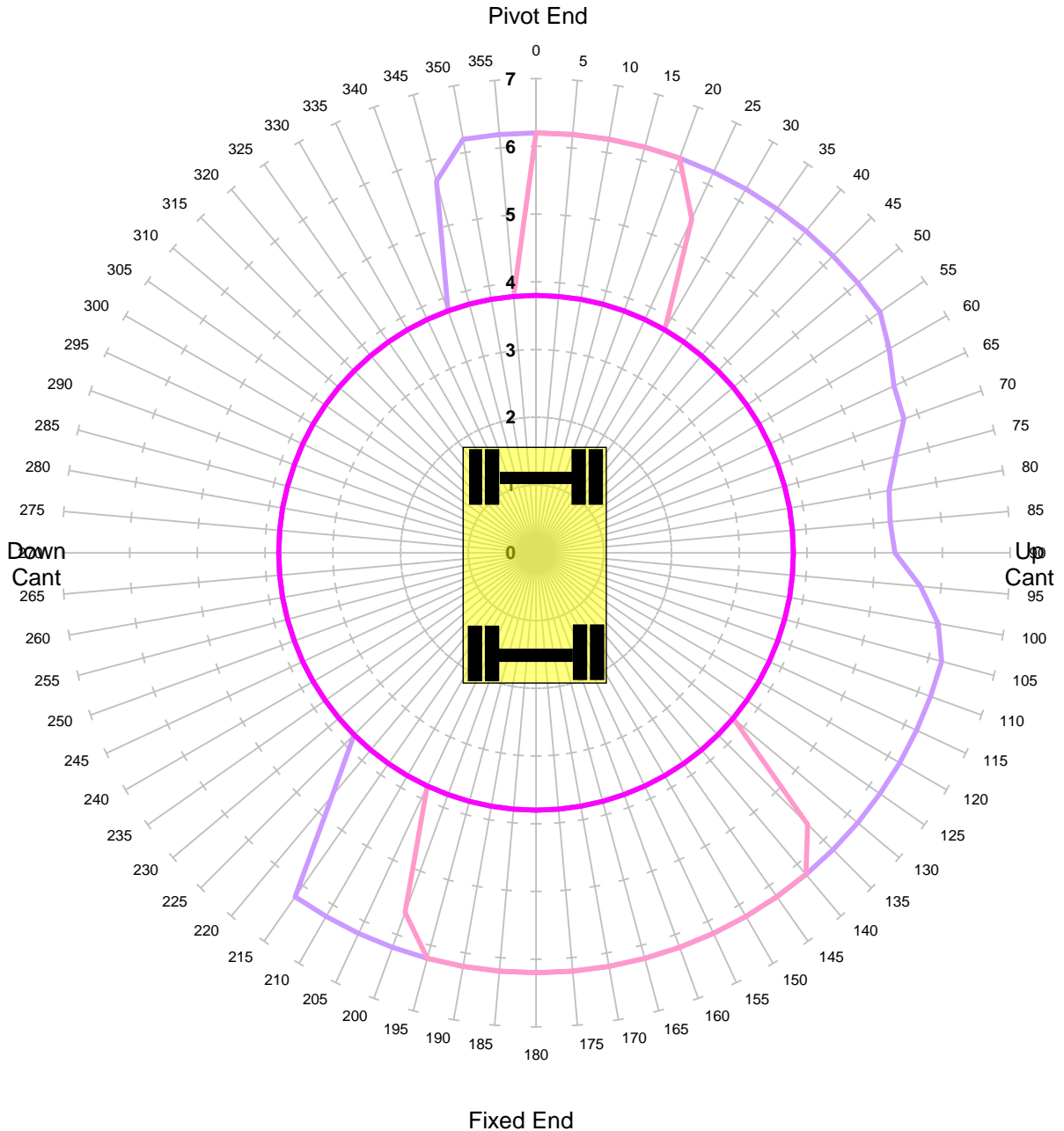

Units in Tonnes

- 1
- 2
- 3
- 4
- 5

| | | | |
|-----------------------------|--------------|-----------------------|----------------|
| MACHINE & MODEL: | Case 988 | REFERENCE: | 99709 940608-1 |
| SERIAL No: | CGG0232265 | DATE OF CHART: | 27-Jan-2022 |
| EQUIPMENT: | 4.29m + 2.1m | SAFETY FACTOR: | 44.0% |
| COMMENT: | | | |



KING TRANSPORT EQUIPMENT LTD
Max Capacity Contours of Radius(m) Plots 2.1m Dipper
Gradient 1 in -25 Height 2m Lift ALP1
Locked Rail Cant -150mm - Tandem Lift

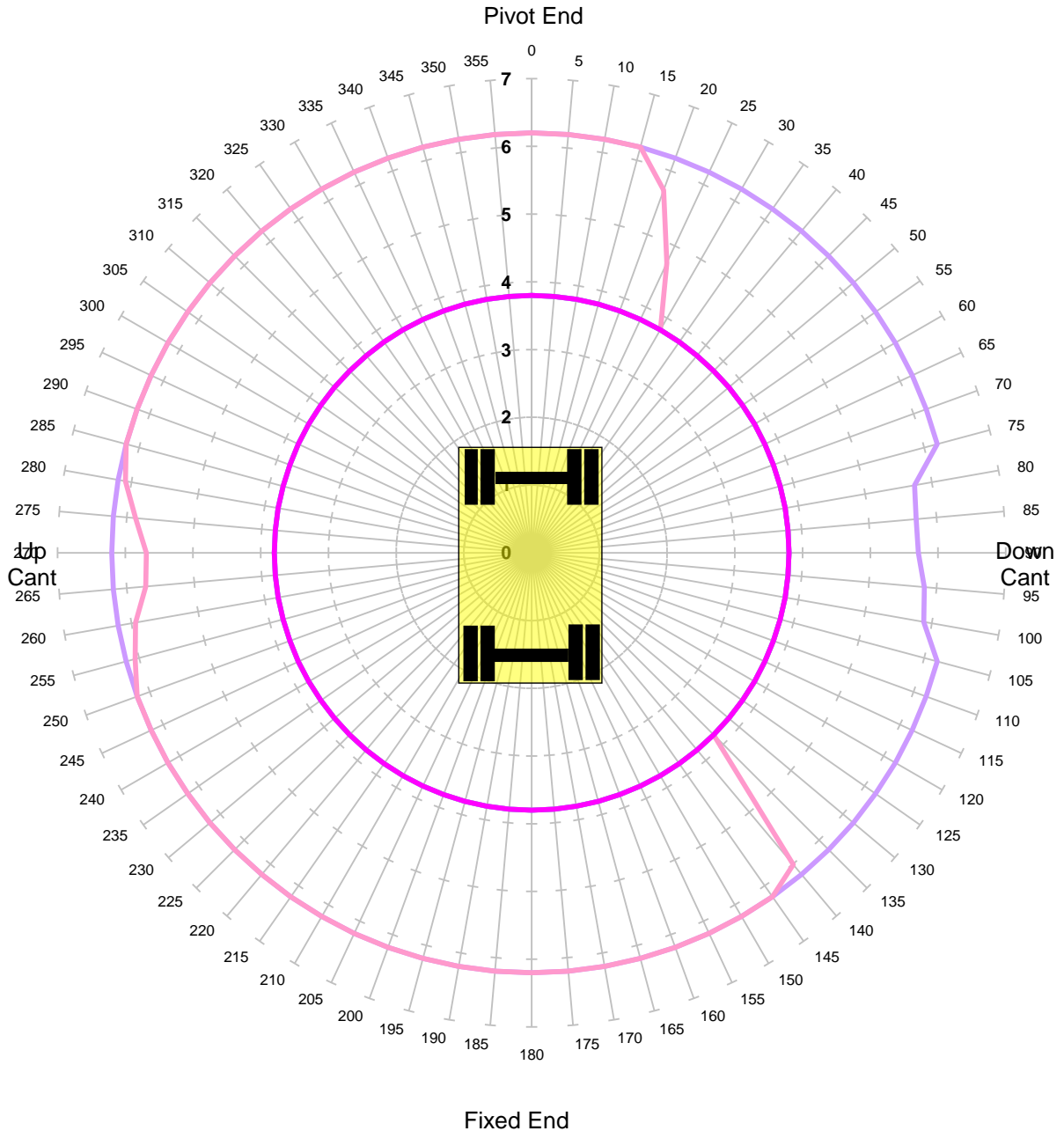

Units in Tonnes

- 1
- 2
- 3
- 4
- 5

| | | | |
|-----------------------------|--------------|-----------------------|----------------|
| MACHINE & MODEL: | Case 988 | REFERENCE: | 99709 940608-1 |
| SERIAL No: | CGG0232265 | DATE OF CHART: | 27-Jan-2022 |
| EQUIPMENT: | 4.29m + 2.1m | SAFETY FACTOR: | 59.0% |
| COMMENT: | | | |



KING TRANSPORT EQUIPMENT LTD
Max Capacity Contours of Radius(m) Plots 2.1m Dipper
Gradient 1 in -25 Height 2m Lift ALP1
Locked Rail Cant -50mm - Tandem Lift

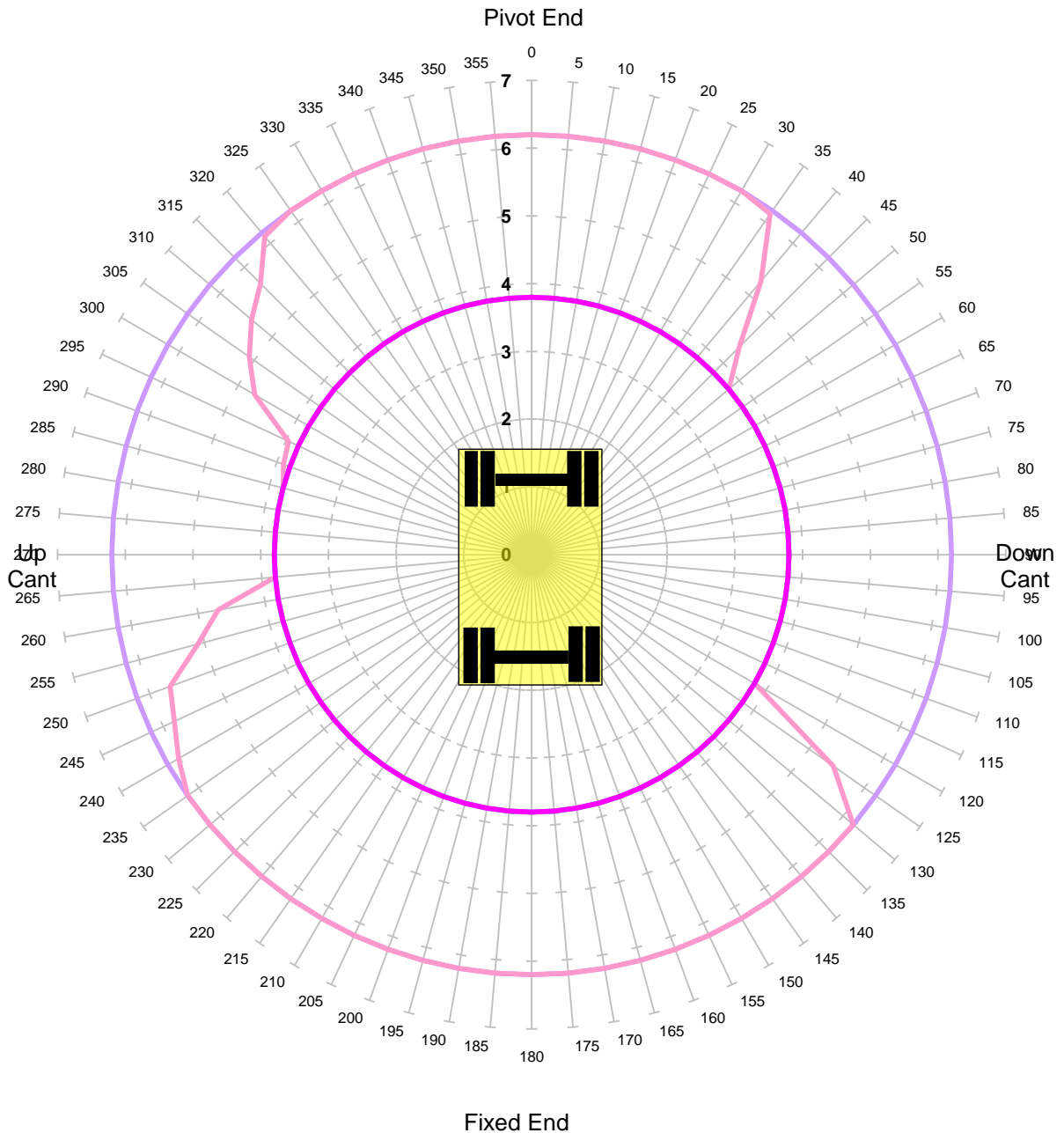

Units in Tonnes

- 1
- 2
- 3
- 4
- 5

| | | | |
|-----------------------------|--------------|-----------------------|----------------|
| MACHINE & MODEL: | Case 988 | REFERENCE: | 99709 940608-1 |
| SERIAL No: | CGG0232265 | DATE OF CHART: | 27-Jan-2022 |
| EQUIPMENT: | 4.29m + 2.1m | SAFETY FACTOR: | 59.0% |
| COMMENT: | | | |



KING TRANSPORT EQUIPMENT LTD
Max Capacity Contours of Radius(m) Plots 2.1m Dipper
Gradient 1 in -25 Height 2m Lift ALP1
Locked Rail Cant 50mm - Tandem Lift

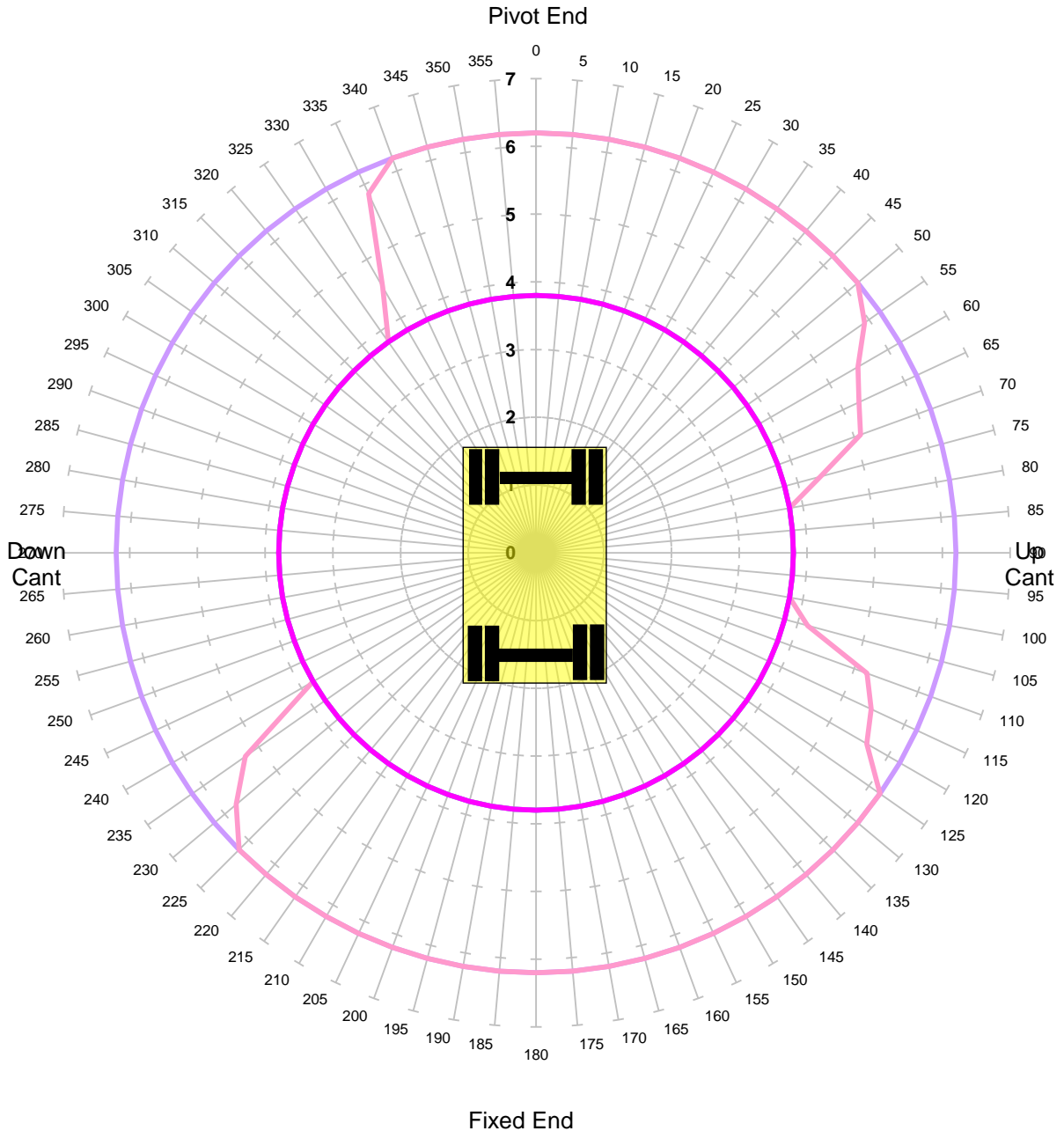

Units in Tonnes

- 1
- 2
- 3
- 4
- 5

| | | | |
|-----------------------------|--------------|-----------------------|----------------|
| MACHINE & MODEL: | Case 988 | REFERENCE: | 99709 940608-1 |
| SERIAL No: | CGG0232265 | DATE OF CHART: | 27-Jan-2022 |
| EQUIPMENT: | 4.29m + 2.1m | SAFETY FACTOR: | 59.0% |
| COMMENT: | | | |



KING TRANSPORT EQUIPMENT LTD
Max Capacity Contours of Radius(m) Plots 2.1m Dipper
Gradient 1 in -25 Height 2m Lift ALP1
Locked Rail Cant 150mm - Tandem Lift

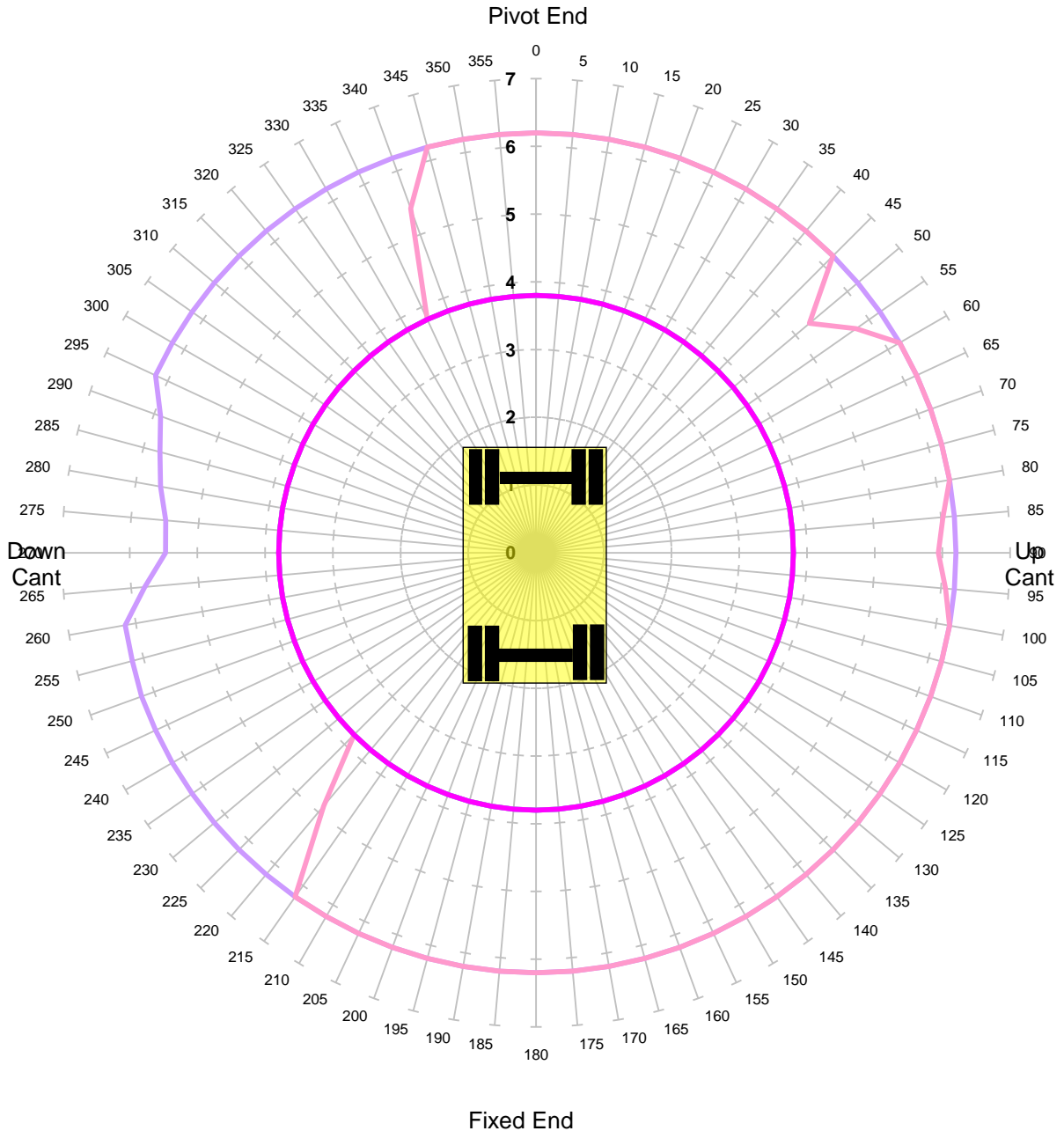

Units in Tonnes

- 1
- 2
- 3
- 4
- 5

| | | | |
|-----------------------------|--------------|-----------------------|----------------|
| MACHINE & MODEL: | Case 988 | REFERENCE: | 99709 940608-1 |
| SERIAL No: | CGG0232265 | DATE OF CHART: | 27-Jan-2022 |
| EQUIPMENT: | 4.29m + 2.1m | SAFETY FACTOR: | 59.0% |
| COMMENT: | | | |



KING TRANSPORT EQUIPMENT LTD
Max Capacity Contours of Radius(m) Plots 2.1m Dipper
Level Ground Height 2m Lift ALP1
Unlocked Road - Tandem Lift

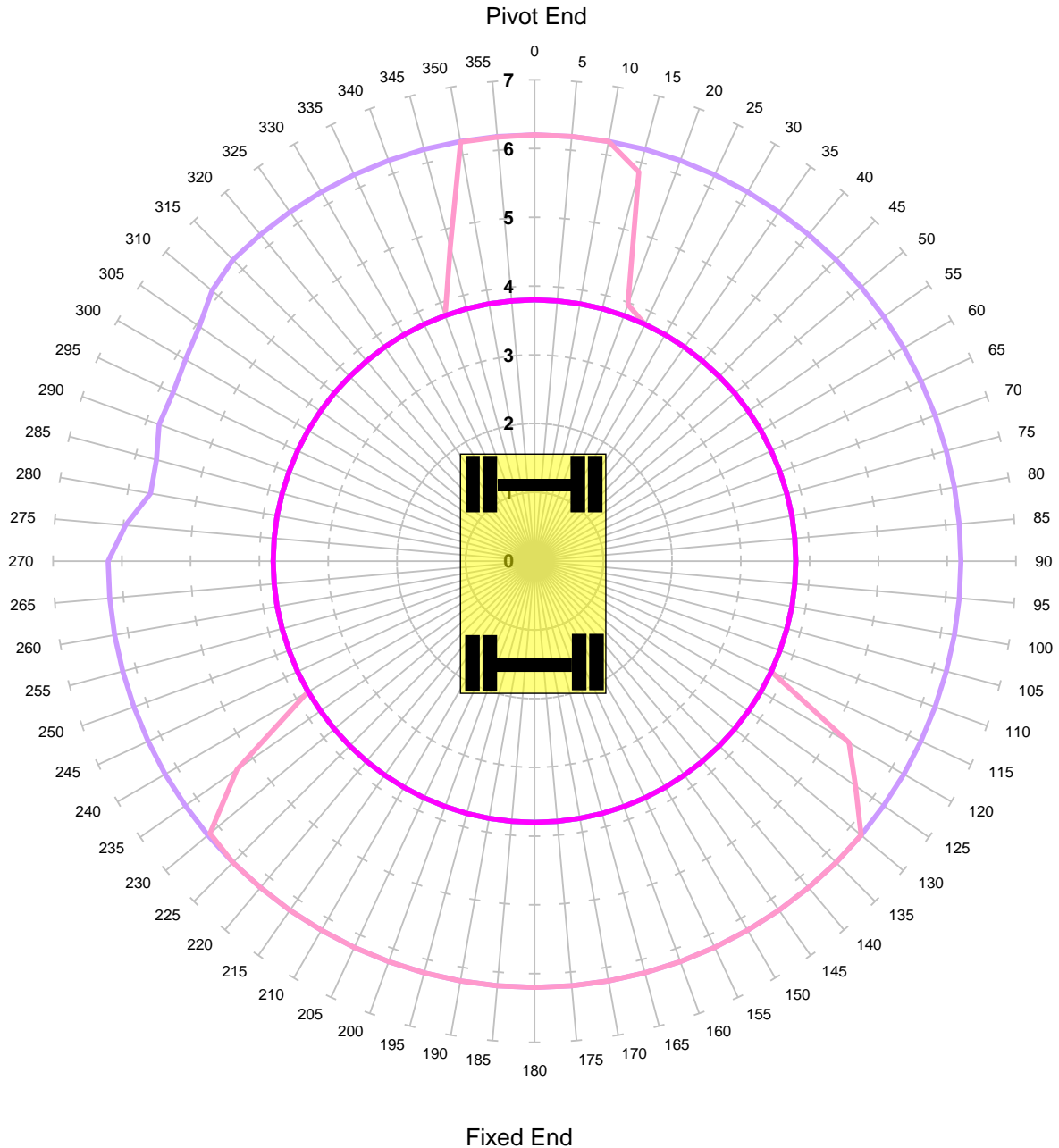

Units in Tonnes

- 1
- 2
- 3
- 4
- 5

| | | | |
|-----------------------------|--------------|-----------------------|----------------|
| MACHINE & MODEL: | Case 988 | REFERENCE: | 99709 940608-1 |
| SERIAL No: | CGG0232265 | DATE OF CHART: | 27-Jan-2022 |
| EQUIPMENT: | 4.29m + 2.1m | SAFETY FACTOR: | 50.0% |
| COMMENT: | | | |



KING TRANSPORT EQUIPMENT LTD
Max Capacity Contours of Radius(m) Plots 2.1m Dipper
Level Ground Height 2m Lift ALP1
Locked Road - Tandem Lift

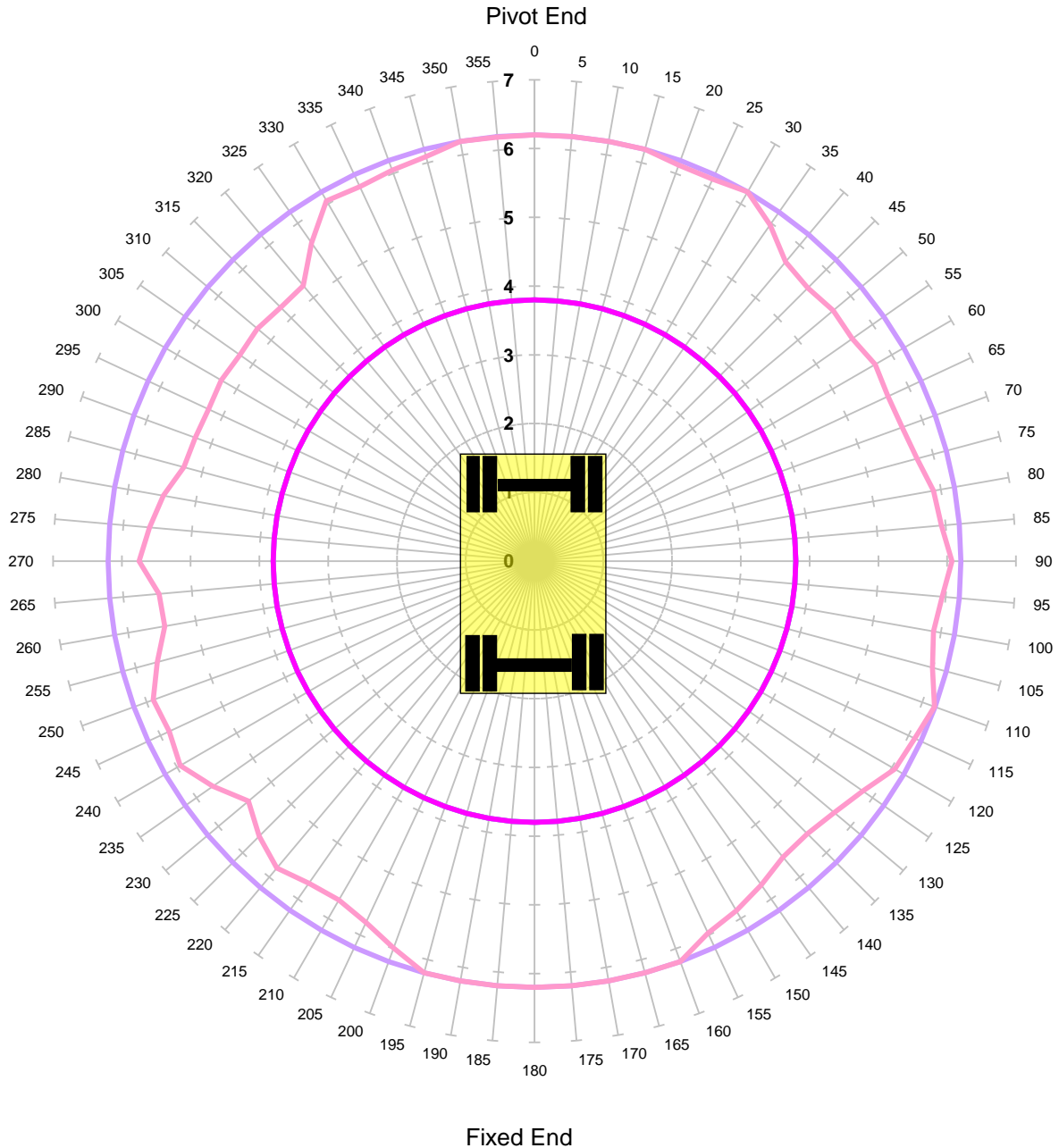

Units in Tonnes

- 1
- 2
- 3
- 4
- 5

| | | | |
|-----------------------------|--------------|-----------------------|----------------|
| MACHINE & MODEL: | Case 988 | REFERENCE: | 99709 940608-1 |
| SERIAL No: | CGG0232265 | DATE OF CHART: | 27-Jan-2022 |
| EQUIPMENT: | 4.29m + 2.1m | SAFETY FACTOR: | 50.0% |
| COMMENT: | | | |



KING TRANSPORT EQUIPMENT LTD
Max Capacity Contours of Radius(m) Plots 2.1m Dipper
Gradient 1 in -25 Height 2m Lift QH
Unlocked Rail Cant -150mm

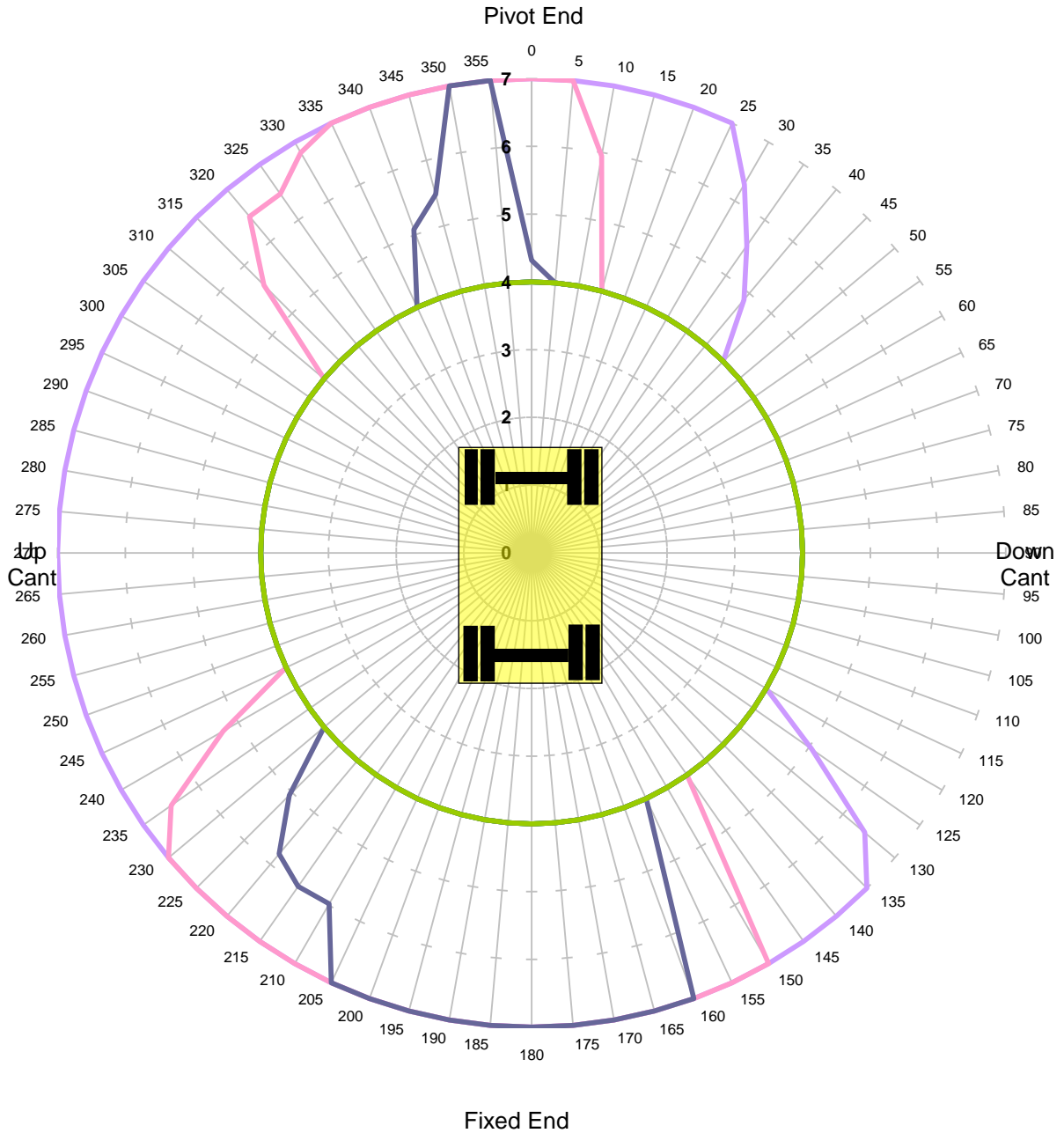

Units in Tonnes

- 1
- 2
- 3
- 4
- 5
- 6
- 7
- 8
- 9
- 10

| | | | |
|-----------------------------|--------------|-----------------------|----------------|
| MACHINE & MODEL: | Case 988 | REFERENCE: | 99709 940608-1 |
| SERIAL No: | CGG0232265 | DATE OF CHART: | 27-Jan-2022 |
| EQUIPMENT: | 4.29m + 2.1m | SAFETY FACTOR: | 67.0% |
| COMMENT: | | | |



KING TRANSPORT EQUIPMENT LTD
Max Capacity Contours of Radius(m) Plots 2.1m Dipper
Gradient 1 in -25 Height 2m Lift QH
Unlocked Rail Cant -50mm

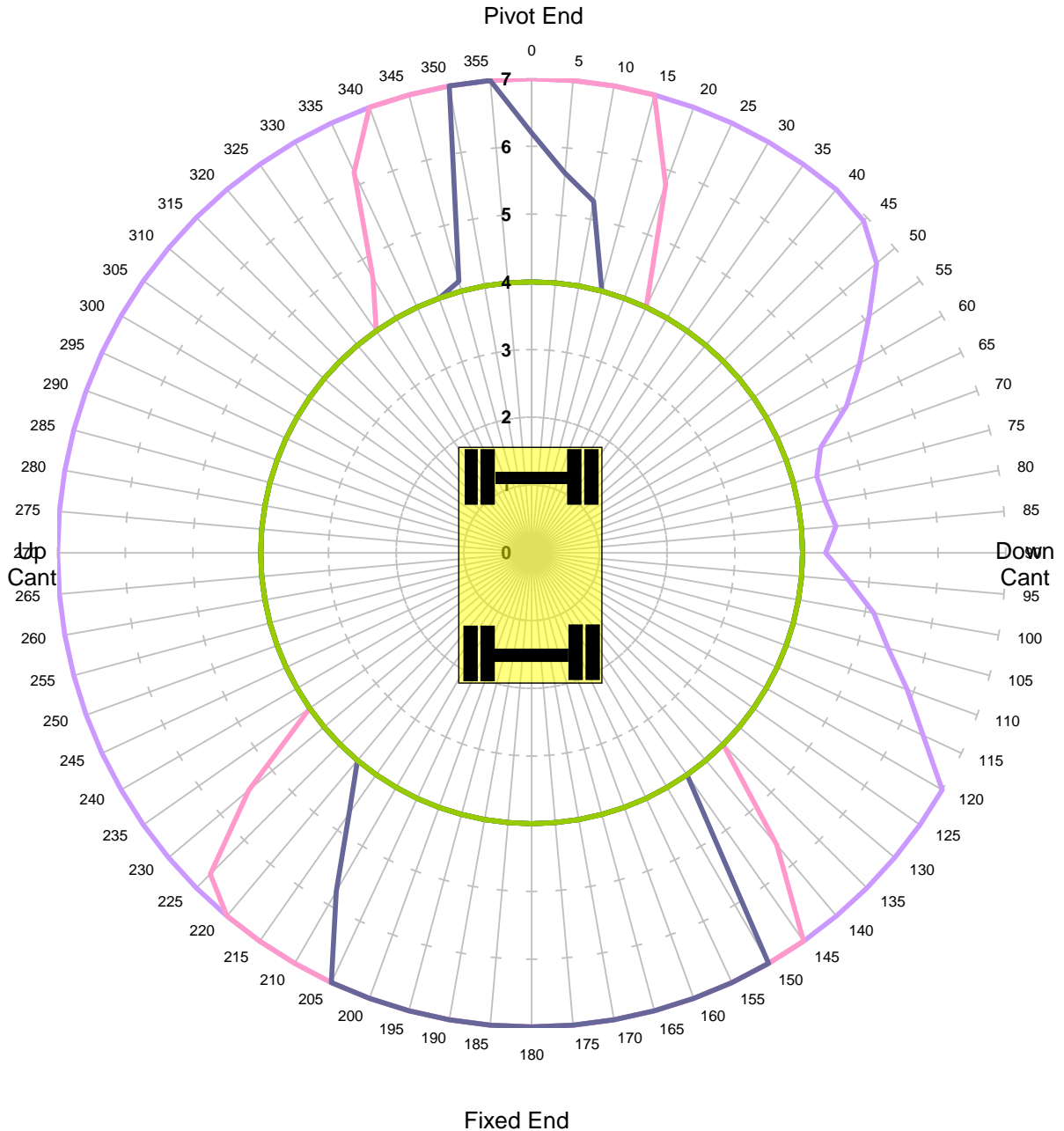

Units in Tonnes

- 1
- 2
- 3
- 4
- 5
- 6
- 7
- 8
- 9
- 10

| | | | |
|-----------------------------|--------------|-----------------------|----------------|
| MACHINE & MODEL: | Case 988 | REFERENCE: | 99709 940608-1 |
| SERIAL No: | CGG0232265 | DATE OF CHART: | 27-Jan-2022 |
| EQUIPMENT: | 4.29m + 2.1m | SAFETY FACTOR: | 67.0% |
| COMMENT: | | | |



KING TRANSPORT EQUIPMENT LTD
Max Capacity Contours of Radius(m) Plots 2.1m Dipper
Gradient 1 in -25 Height 2m Lift QH
Unlocked Rail Cant 50mm

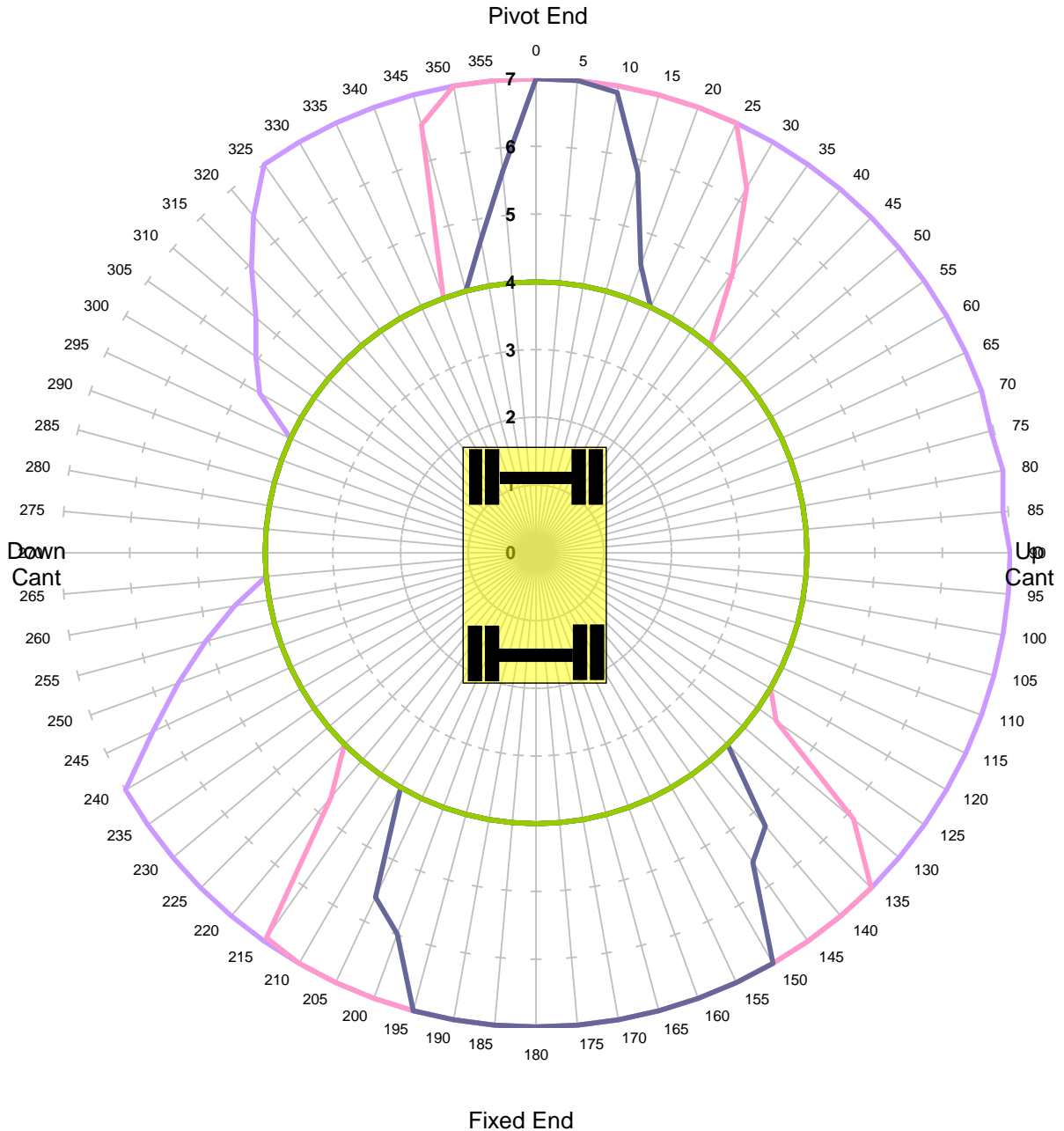

Units in Tonnes

- 1
- 2
- 3
- 4
- 5
- 6
- 7
- 8
- 9
- 10

| | | | |
|-----------------------------|--------------|-----------------------|----------------|
| MACHINE & MODEL: | Case 988 | REFERENCE: | 99709 940608-1 |
| SERIAL No: | CGG0232265 | DATE OF CHART: | 27-Jan-2022 |
| EQUIPMENT: | 4.29m + 2.1m | SAFETY FACTOR: | 67.0% |
| COMMENT: | | | |



KING TRANSPORT EQUIPMENT LTD
Max Capacity Contours of Radius(m) Plots 2.1m Dipper
Gradient 1 in -25 Height 2m Lift QH
Unlocked Rail Cant 150mm

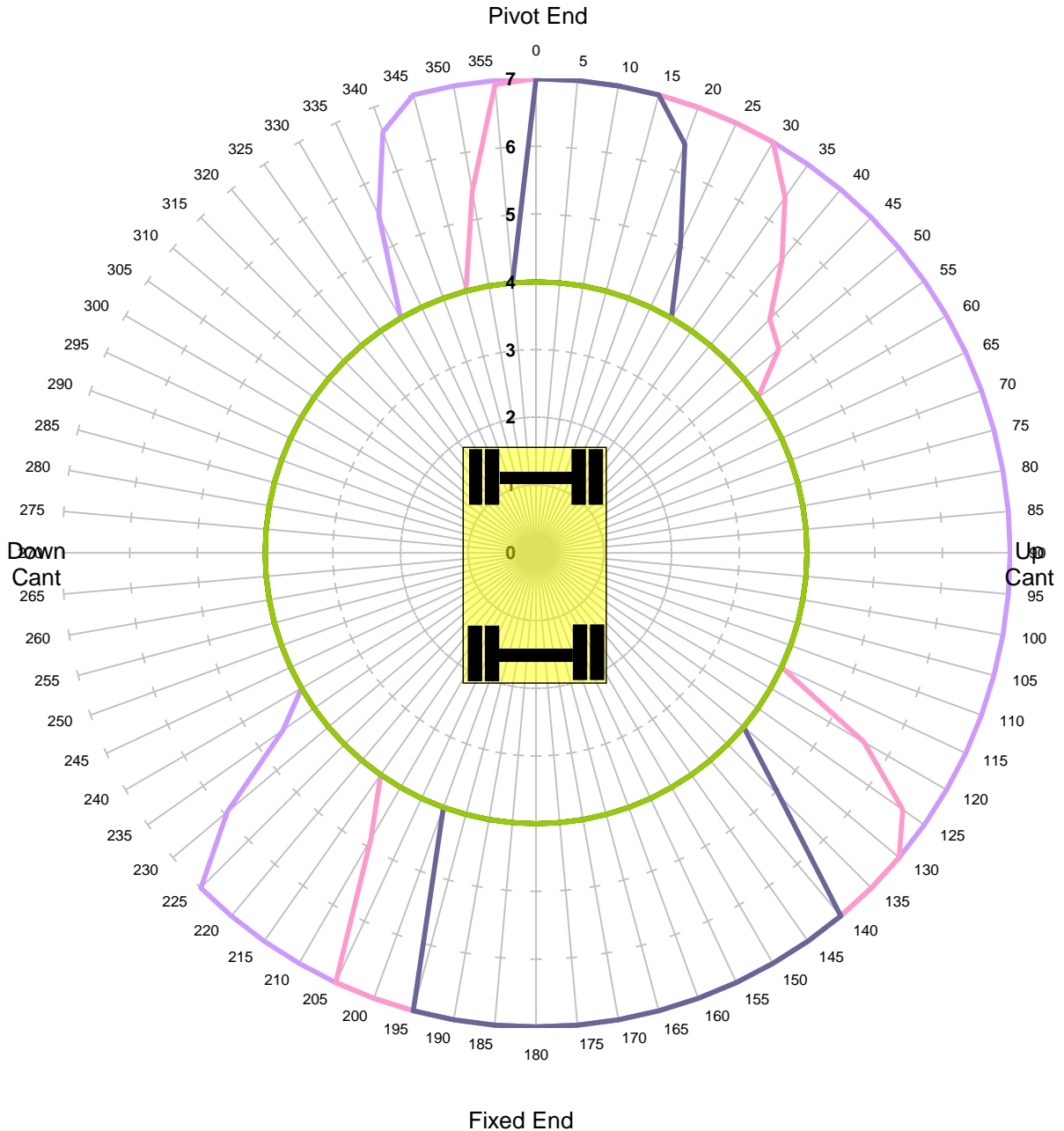

Units in Tonnes

- 1
- 2
- 3
- 4
- 5
- 6
- 7
- 8
- 9
- 10

| | | | |
|-----------------------------|--------------|-----------------------|----------------|
| MACHINE & MODEL: | Case 988 | REFERENCE: | 99709 940608-1 |
| SERIAL No: | CGG0232265 | DATE OF CHART: | 27-Jan-2022 |
| EQUIPMENT: | 4.29m + 2.1m | SAFETY FACTOR: | 67.0% |
| COMMENT: | | | |



KING TRANSPORT EQUIPMENT LTD
Max Capacity Contours of Radius(m) Plots 2.1m Dipper
Gradient 1 in -25 Height 2m Lift QH
Locked Rail Cant -150mm

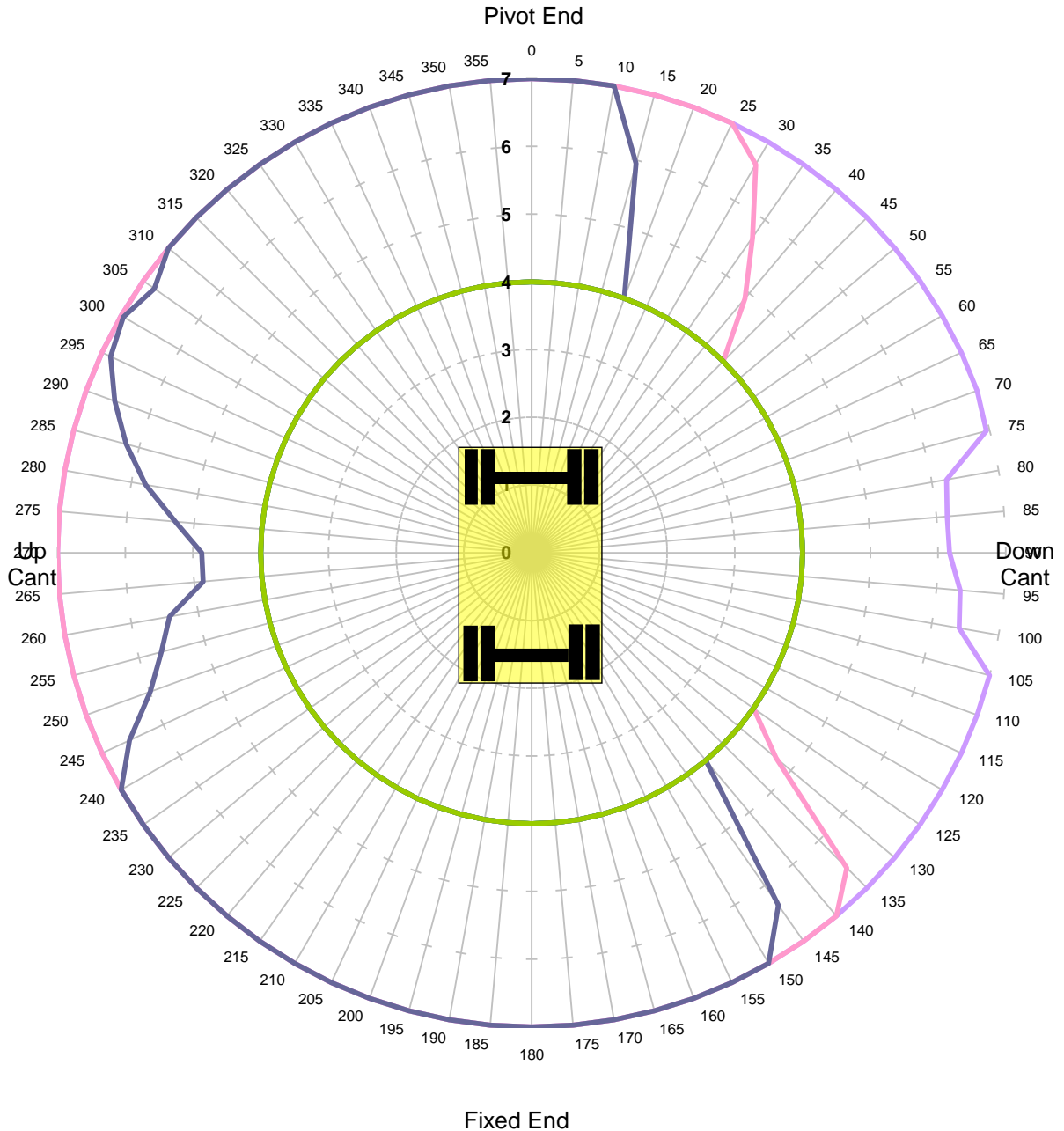

Units in Tonnes

- 1
- 2
- 3
- 4
- 5
- 6
- 7
- 8
- 9
- 10

| | | | |
|-----------------------------|--------------|-----------------------|----------------|
| MACHINE & MODEL: | Case 988 | REFERENCE: | 99709 940608-1 |
| SERIAL No: | CGG0232265 | DATE OF CHART: | 27-Jan-2022 |
| EQUIPMENT: | 4.29m + 2.1m | SAFETY FACTOR: | 90.0% |
| COMMENT: | | | |



KING TRANSPORT EQUIPMENT LTD
Max Capacity Contours of Radius(m) Plots 2.1m Dipper
Gradient 1 in -25 Height 2m Lift QH
Locked Rail Cant -50mm

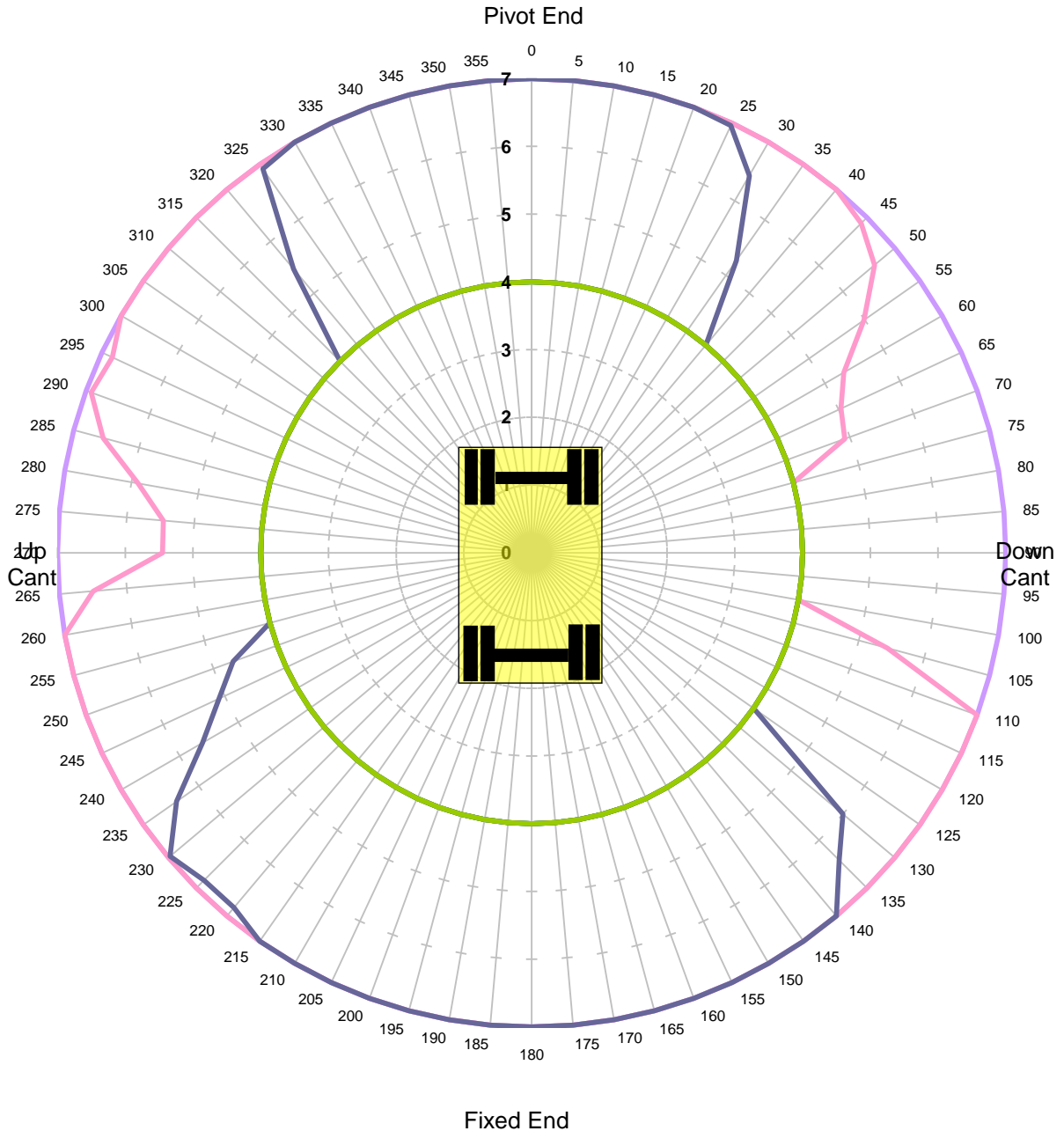

Units in Tonnes

- 1
- 2
- 3
- 4
- 5
- 6
- 7
- 8
- 9
- 10

| | | | |
|-----------------------------|--------------|-----------------------|----------------|
| MACHINE & MODEL: | Case 988 | REFERENCE: | 99709 940608-1 |
| SERIAL No: | CGG0232265 | DATE OF CHART: | 27-Jan-2022 |
| EQUIPMENT: | 4.29m + 2.1m | SAFETY FACTOR: | 90.0% |
| COMMENT: | | | |



KING TRANSPORT EQUIPMENT LTD
Max Capacity Contours of Radius(m) Plots 2.1m Dipper
Gradient 1 in -25 Height 2m Lift QH
Locked Rail Cant 50mm

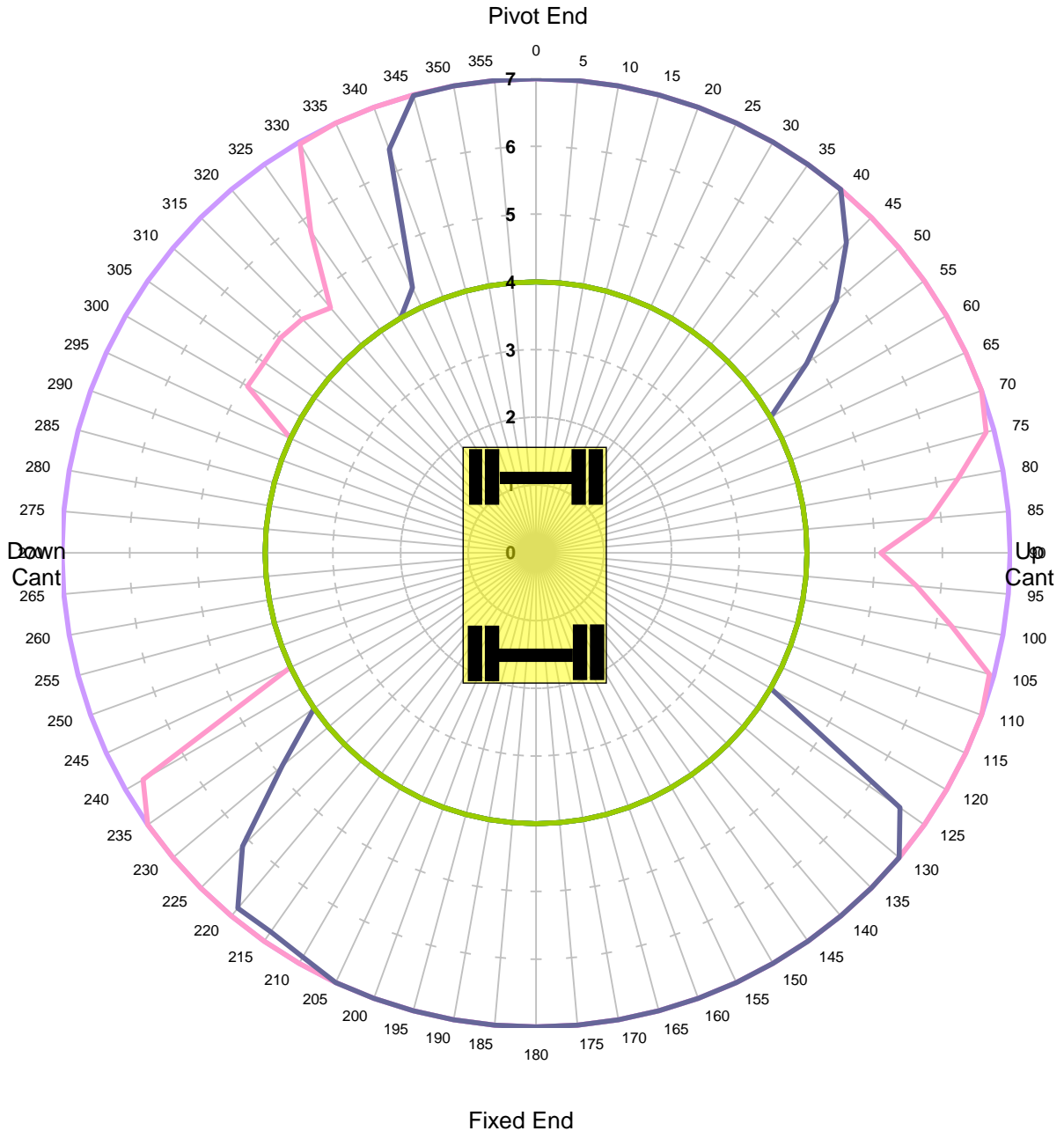

Units in Tonnes

- 1
- 2
- 3
- 4
- 5
- 6
- 7
- 8
- 9
- 10

| | | | |
|-----------------------------|--------------|-----------------------|----------------|
| MACHINE & MODEL: | Case 988 | REFERENCE: | 99709 940608-1 |
| SERIAL No: | CGG0232265 | DATE OF CHART: | 27-Jan-2022 |
| EQUIPMENT: | 4.29m + 2.1m | SAFETY FACTOR: | 90.0% |
| COMMENT: | | | |



KING TRANSPORT EQUIPMENT LTD
Max Capacity Contours of Radius(m) Plots 2.1m Dipper
Gradient 1 in -25 Height 2m Lift QH
Locked Rail Cant 150mm

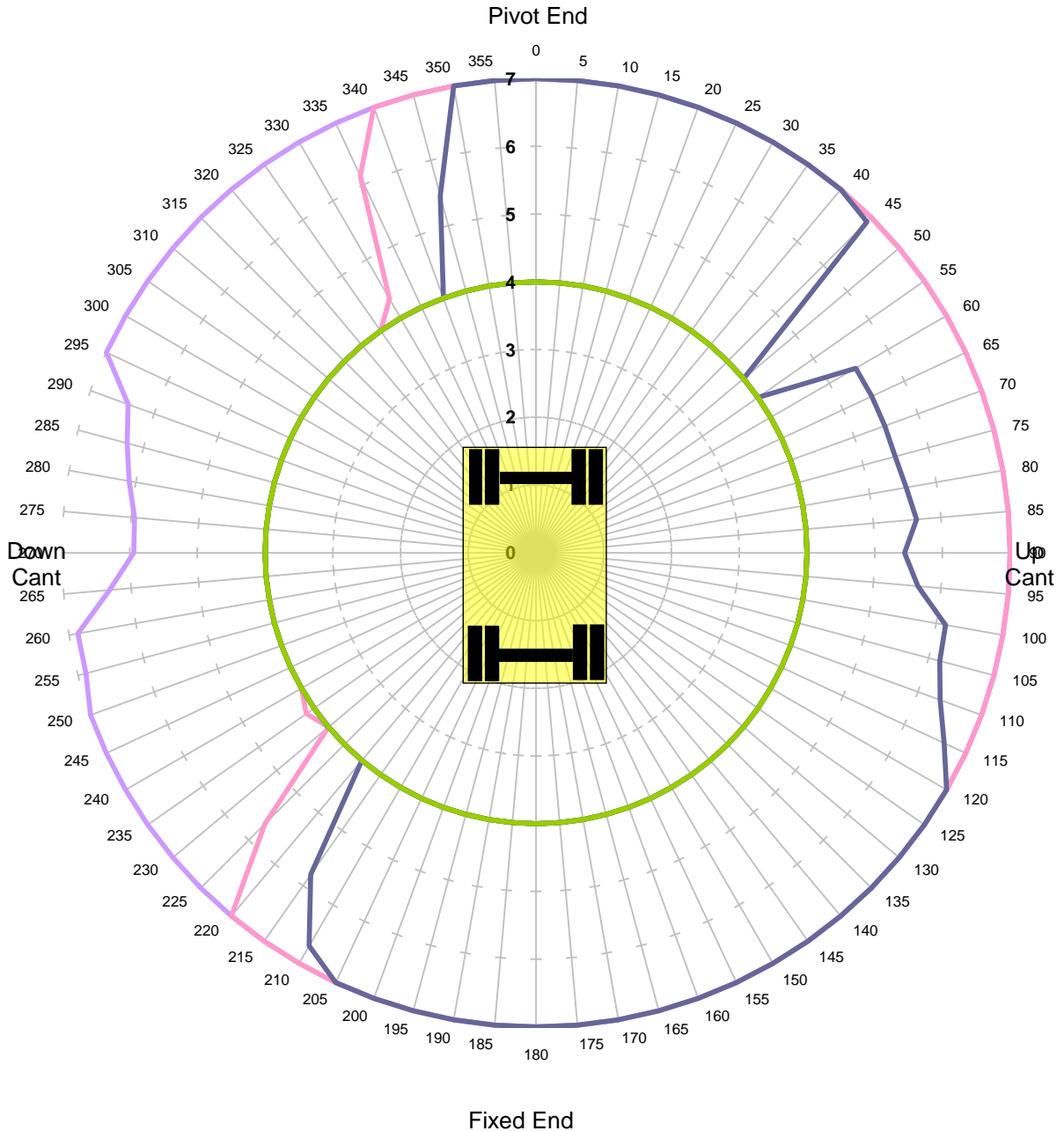

Units in Tonnes

- 1
- 2
- 3
- 4
- 5
- 6
- 7
- 8
- 9
- 10

| | | | |
|-----------------------------|--------------|-----------------------|----------------|
| MACHINE & MODEL: | Case 988 | REFERENCE: | 99709 940608-1 |
| SERIAL No: | CGG0232265 | DATE OF CHART: | 27-Jan-2022 |
| EQUIPMENT: | 4.29m + 2.1m | SAFETY FACTOR: | 90.0% |
| COMMENT: | | | |



KING TRANSPORT EQUIPMENT LTD
Max Capacity Contours of Radius(m) Plots 2.1m Dipper
Level Ground Height 2m Lift QH
Unlocked Road

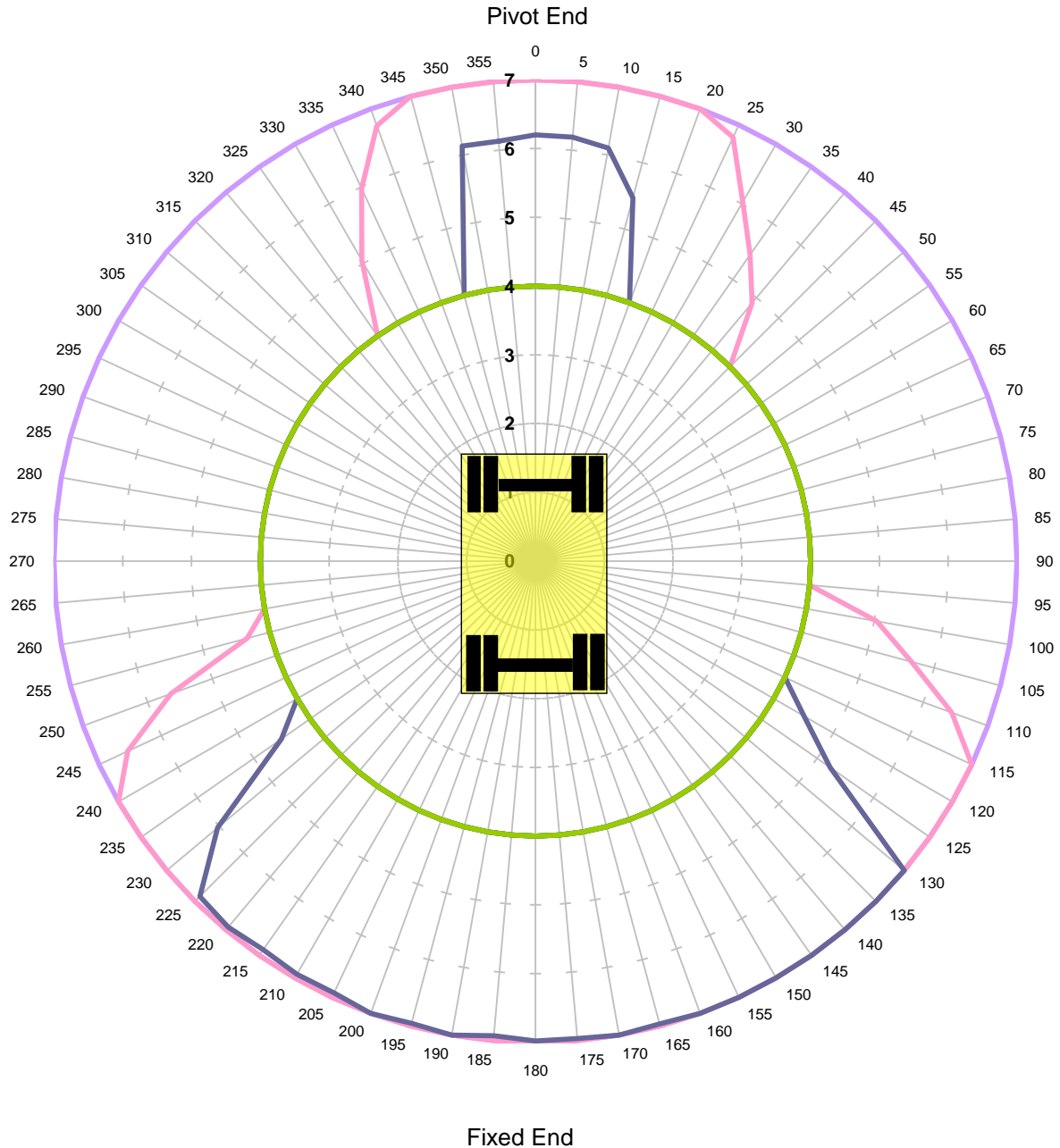

Units in Tonnes

- 1
- 2
- 3
- 4
- 5
- 6
- 7
- 8
- 9
- 10

| | | | |
|-----------------------------|--------------|-----------------------|----------------|
| MACHINE & MODEL: | Case 988 | REFERENCE: | 99709 940608-1 |
| SERIAL No: | CGG0232265 | DATE OF CHART: | 27-Jan-2022 |
| EQUIPMENT: | 4.29m + 2.1m | SAFETY FACTOR: | 75.0% |
| COMMENT: | | | |



KING TRANSPORT EQUIPMENT LTD
Max Capacity Contours of Radius(m) Plots 2.1m Dipper
Level Ground Height 2m Lift QH
Locked Road

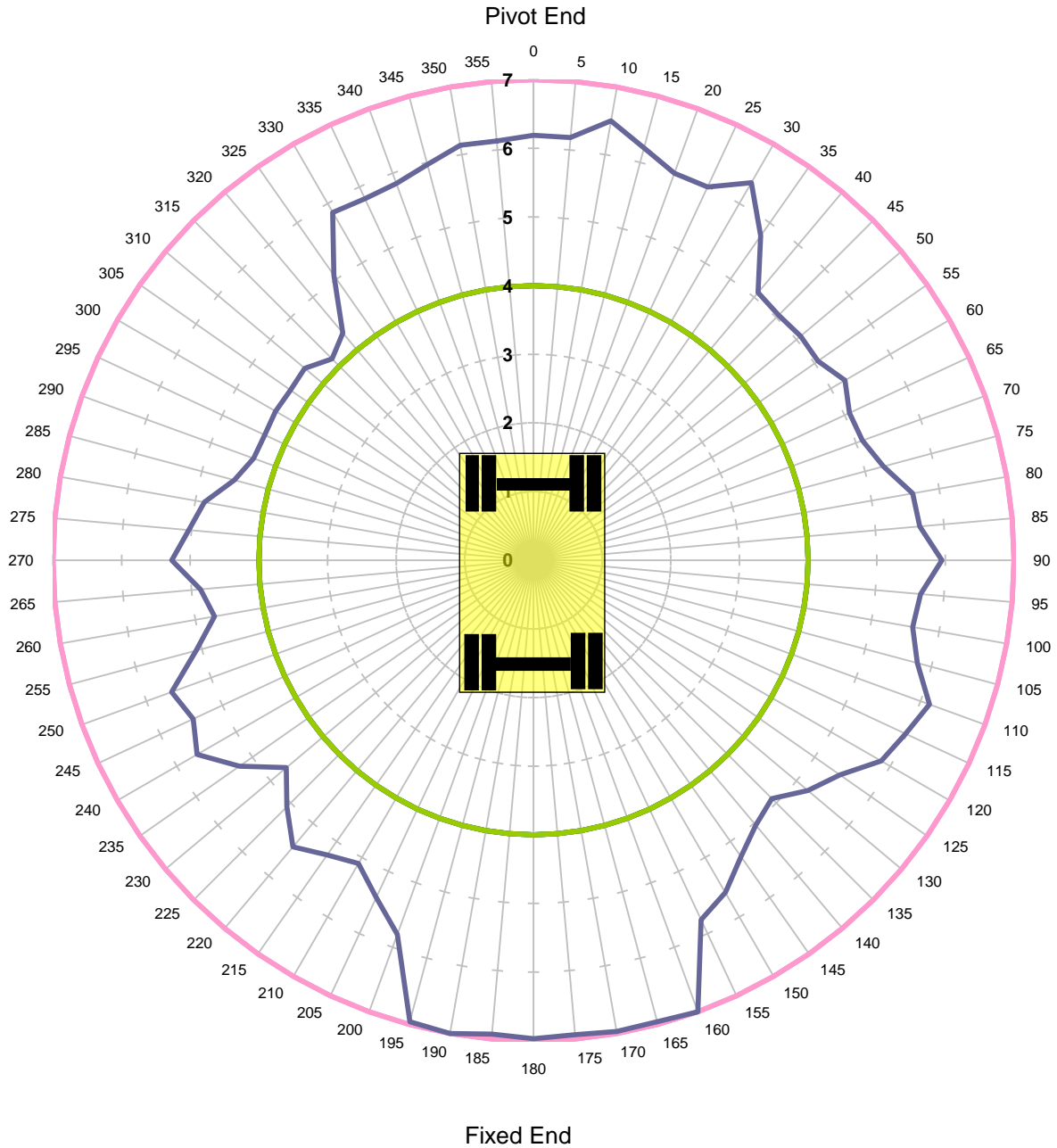

Units in Tonnes

- 1
- 2
- 3
- 4
- 5
- 6
- 7
- 8
- 9
- 10

| | | | |
|-----------------------------|--------------|-----------------------|----------------|
| MACHINE & MODEL: | Case 988 | REFERENCE: | 99709 940608-1 |
| SERIAL No: | CGG0232265 | DATE OF CHART: | 27-Jan-2022 |
| EQUIPMENT: | 4.29m + 2.1m | SAFETY FACTOR: | 75.0% |
| COMMENT: | | | |



KING TRANSPORT EQUIPMENT LTD
Max Capacity Contours of Radius(m) Plots 2.1m Dipper
Gradient 1 in -25 Height 2m Lift QH
Unlocked Rail Cant -150mm - Tandem Lift

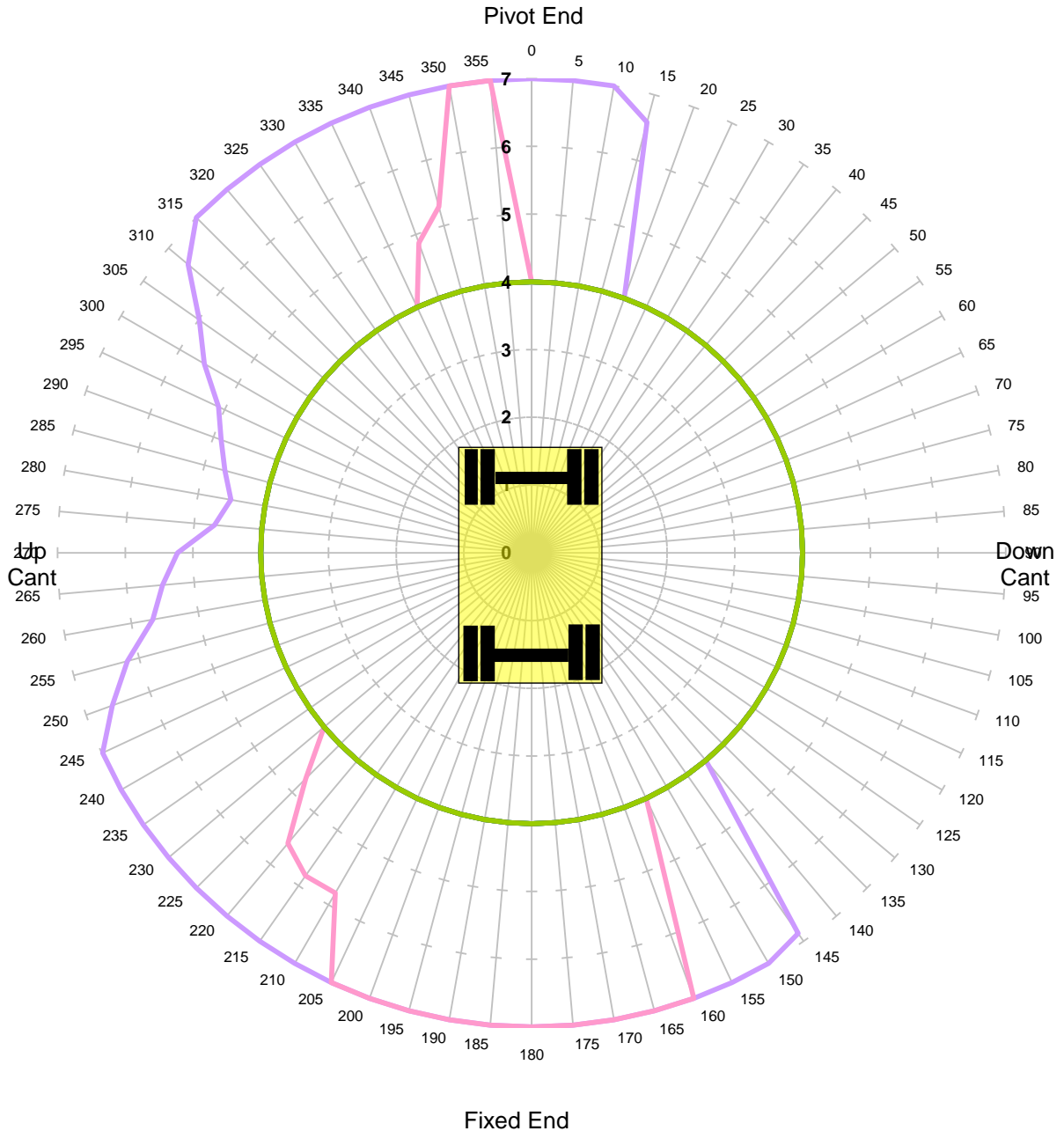

Units in Tonnes

- 1
- 2
- 3
- 4
- 5
- 6
- 7
- 8
- 9
- 10

| | | | |
|-----------------------------|--------------|-----------------------|----------------|
| MACHINE & MODEL: | Case 988 | REFERENCE: | 99709 940608-1 |
| SERIAL No: | CGG0232265 | DATE OF CHART: | 27-Jan-2022 |
| EQUIPMENT: | 4.29m + 2.1m | SAFETY FACTOR: | 44.0% |
| COMMENT: | | | |



KING TRANSPORT EQUIPMENT LTD
Max Capacity Contours of Radius(m) Plots 2.1m Dipper
Gradient 1 in -25 Height 2m Lift QH
Unlocked Rail Cant -50mm - Tandem Lift

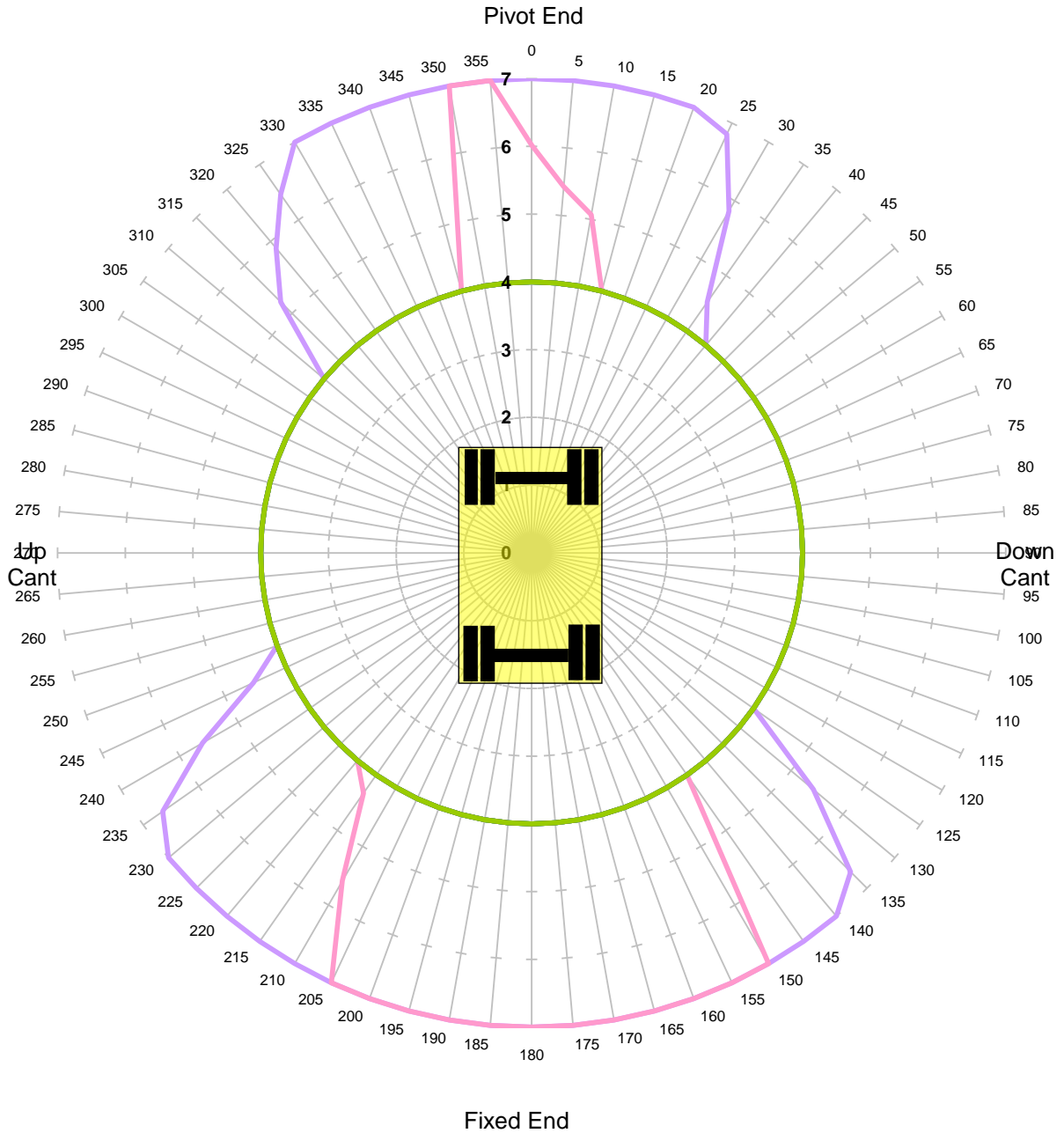

Units in Tonnes

- 1
- 2
- 3
- 4
- 5
- 6
- 7
- 8
- 9
- 10

| | | | |
|-----------------------------|--------------|-----------------------|----------------|
| MACHINE & MODEL: | Case 988 | REFERENCE: | 99709 940608-1 |
| SERIAL No: | CGG0232265 | DATE OF CHART: | 27-Jan-2022 |
| EQUIPMENT: | 4.29m + 2.1m | SAFETY FACTOR: | 44.0% |
| COMMENT: | | | |



KING TRANSPORT EQUIPMENT LTD
Max Capacity Contours of Radius(m) Plots 2.1m Dipper
Gradient 1 in -25 Height 2m Lift QH
Unlocked Rail Cant 50mm - Tandem Lift

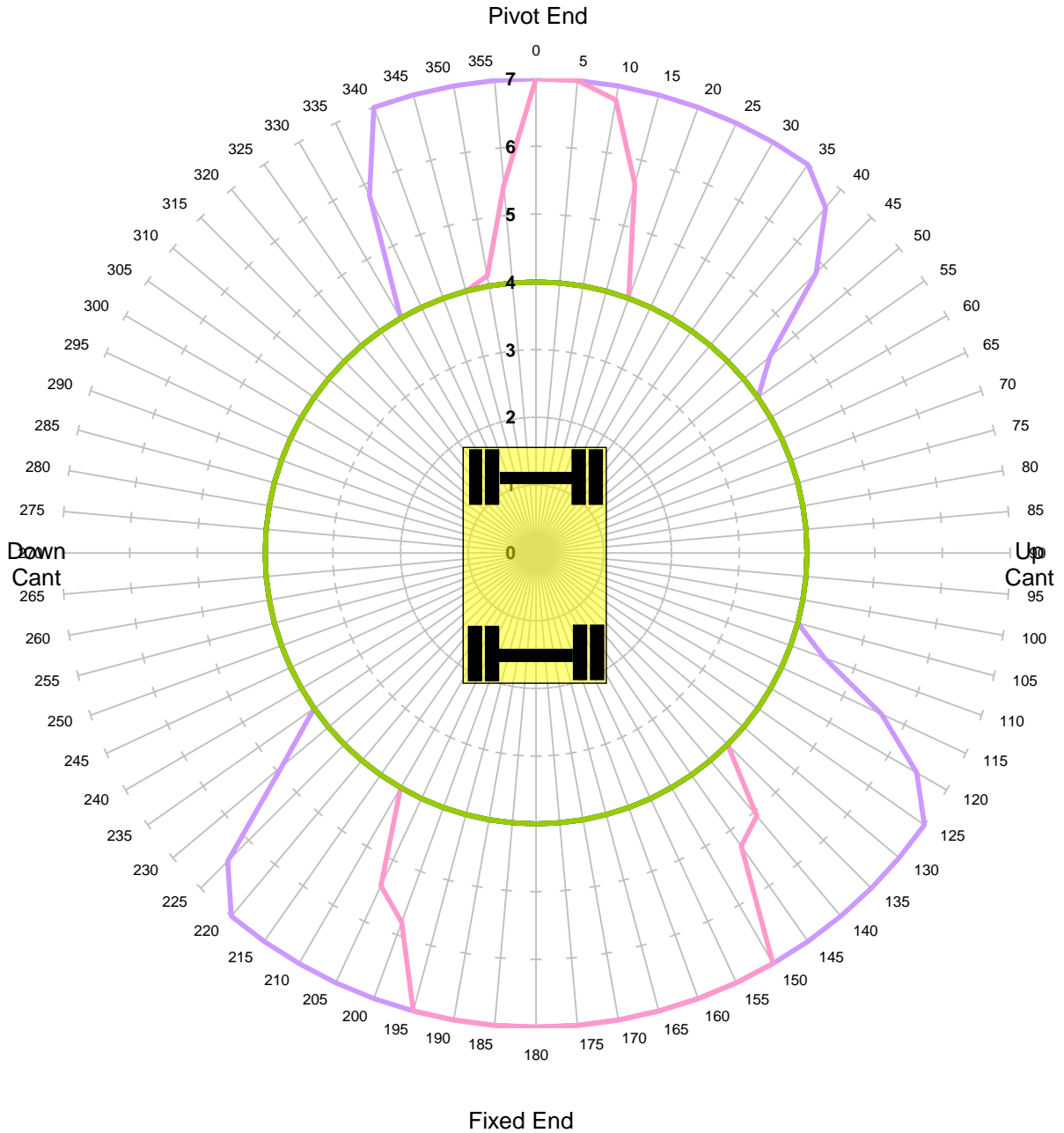

Units in Tonnes

- 1
- 2
- 3
- 4
- 5
- 6
- 7
- 8
- 9
- 10

| | | | |
|-----------------------------|--------------|-----------------------|----------------|
| MACHINE & MODEL: | Case 988 | REFERENCE: | 99709 940608-1 |
| SERIAL No: | CGG0232265 | DATE OF CHART: | 27-Jan-2022 |
| EQUIPMENT: | 4.29m + 2.1m | SAFETY FACTOR: | 44.0% |
| COMMENT: | | | |



KING TRANSPORT EQUIPMENT LTD
Max Capacity Contours of Radius(m) Plots 2.1m Dipper
Gradient 1 in -25 Height 2m Lift QH
Unlocked Rail Cant 150mm - Tandem Lift

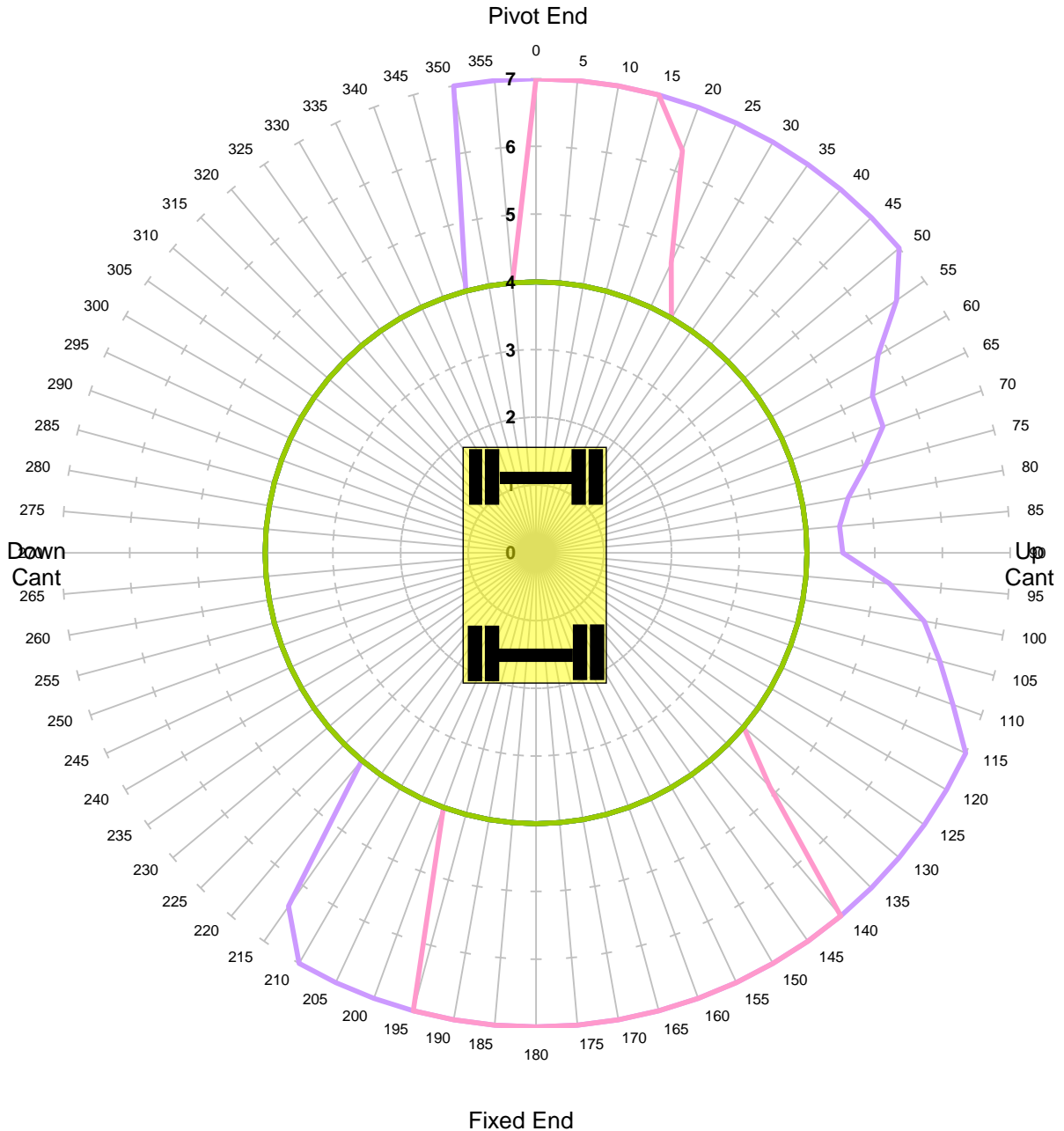

Units in Tonnes

- 1
- 2
- 3
- 4
- 5
- 6
- 7
- 8
- 9
- 10

| | | | |
|-----------------------------|--------------|-----------------------|----------------|
| MACHINE & MODEL: | Case 988 | REFERENCE: | 99709 940608-1 |
| SERIAL No: | CGG0232265 | DATE OF CHART: | 27-Jan-2022 |
| EQUIPMENT: | 4.29m + 2.1m | SAFETY FACTOR: | 44.0% |
| COMMENT: | | | |



KING TRANSPORT EQUIPMENT LTD
Max Capacity Contours of Radius(m) Plots 2.1m Dipper
Gradient 1 in -25 Height 2m Lift QH
Locked Rail Cant -150mm - Tandem Lift

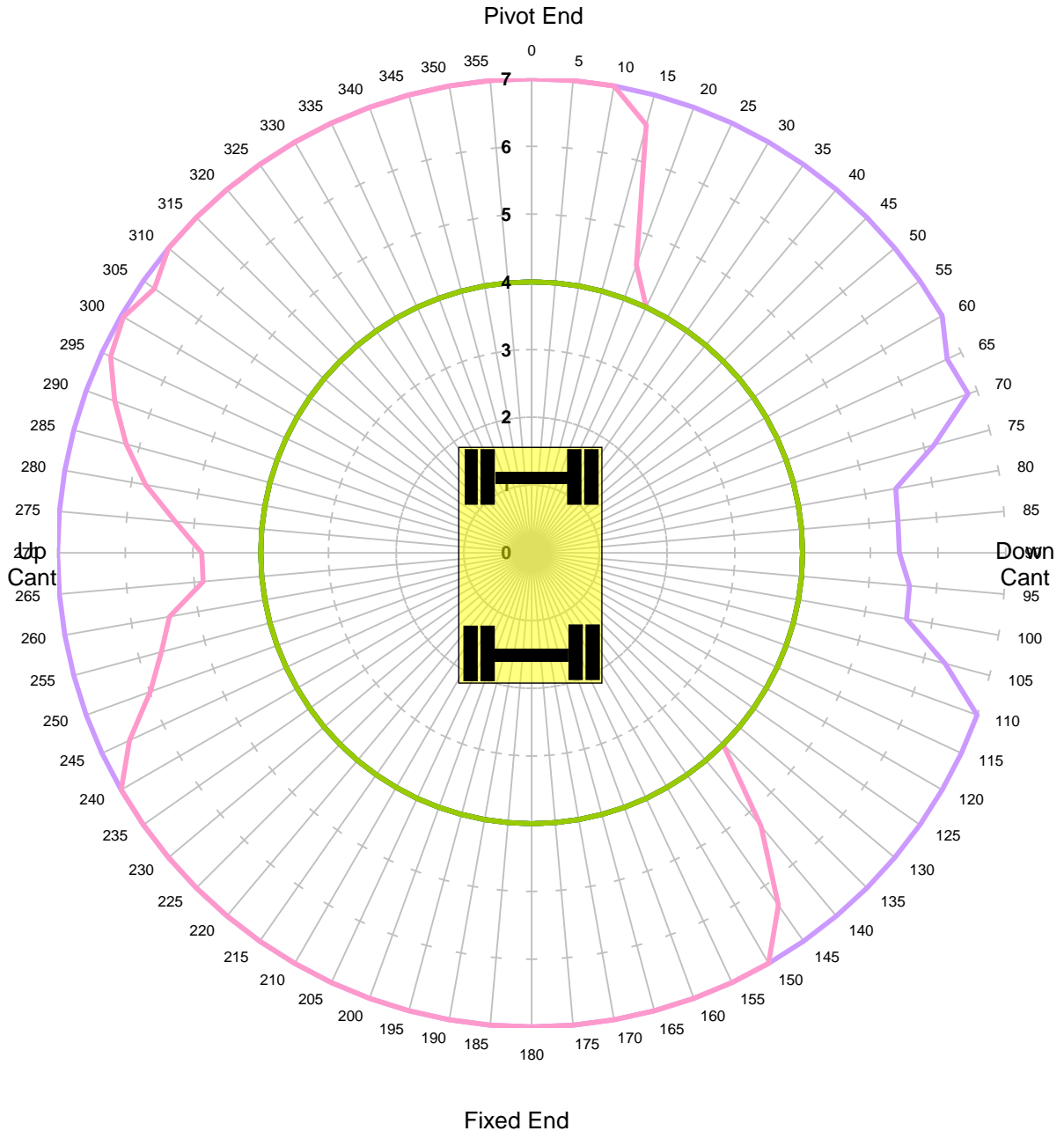

Units in Tonnes

- 1
- 2
- 3
- 4
- 5
- 6
- 7
- 8
- 9
- 10

| | | | |
|-----------------------------|--------------|-----------------------|----------------|
| MACHINE & MODEL: | Case 988 | REFERENCE: | 99709 940608-1 |
| SERIAL No: | CGG0232265 | DATE OF CHART: | 27-Jan-2022 |
| EQUIPMENT: | 4.29m + 2.1m | SAFETY FACTOR: | 59.0% |
| COMMENT: | | | |



KING TRANSPORT EQUIPMENT LTD
Max Capacity Contours of Radius(m) Plots 2.1m Dipper
Gradient 1 in -25 Height 2m Lift QH
Locked Rail Cant -50mm - Tandem Lift

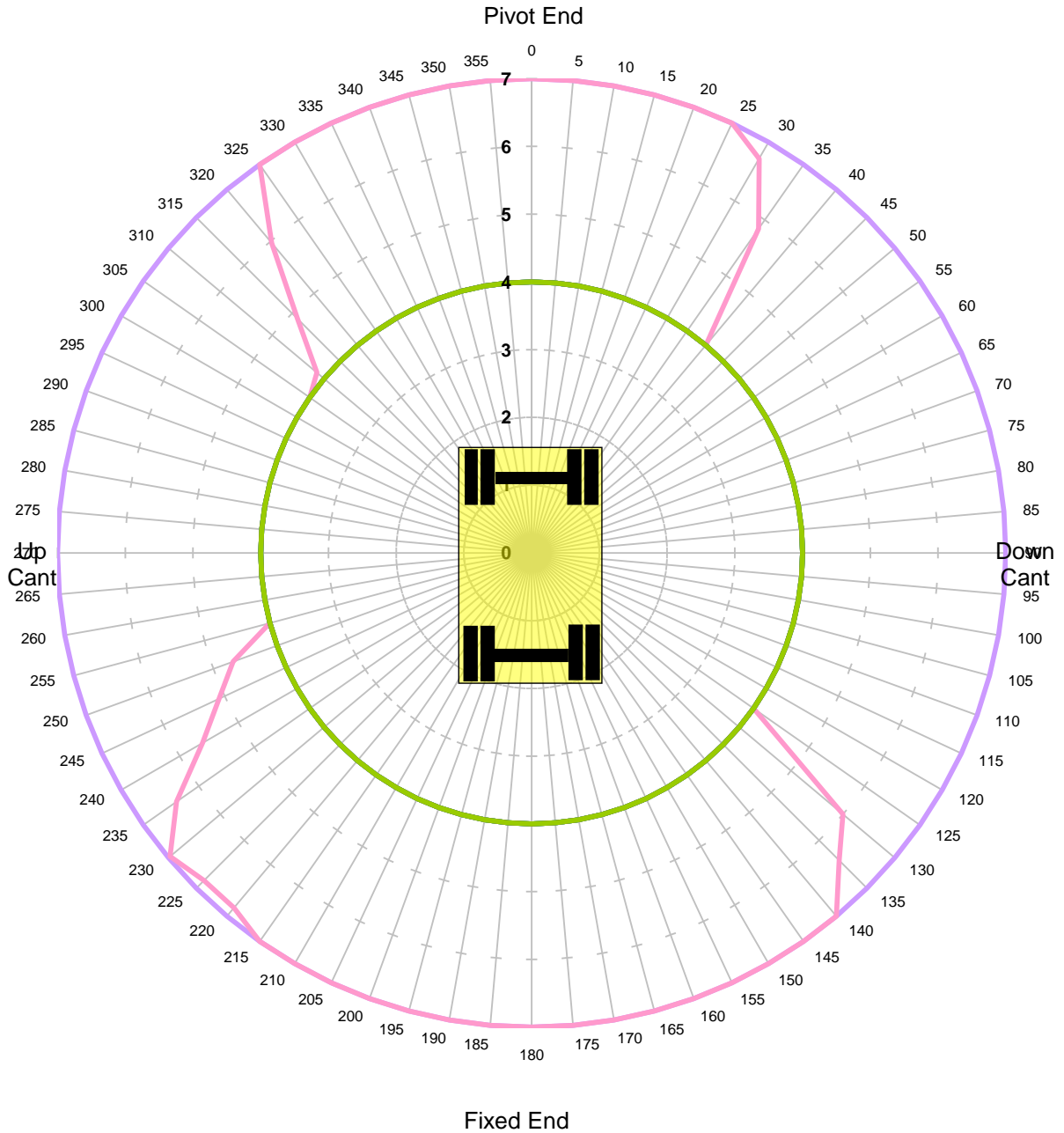

Units in Tonnes

- 1
- 2
- 3
- 4
- 5
- 6
- 7
- 8
- 9
- 10

| | | | |
|-----------------------------|--------------|-----------------------|----------------|
| MACHINE & MODEL: | Case 988 | REFERENCE: | 99709 940608-1 |
| SERIAL No: | CGG0232265 | DATE OF CHART: | 27-Jan-2022 |
| EQUIPMENT: | 4.29m + 2.1m | SAFETY FACTOR: | 59.0% |
| COMMENT: | | | |



KING TRANSPORT EQUIPMENT LTD
Max Capacity Contours of Radius(m) Plots 2.1m Dipper
Gradient 1 in -25 Height 2m Lift QH
Locked Rail Cant 50mm - Tandem Lift

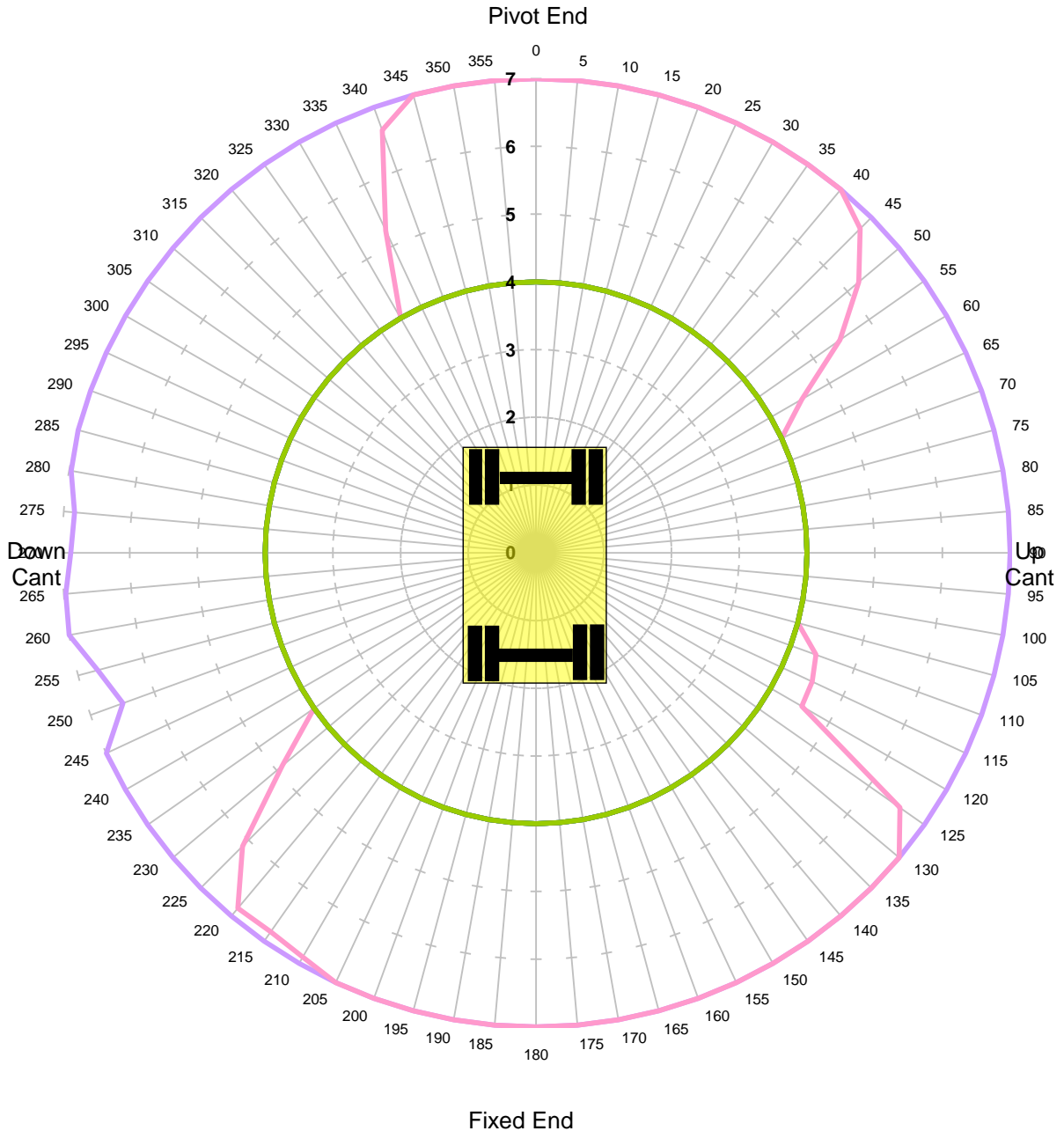

Units in Tonnes

- 1
- 2
- 3
- 4
- 5
- 6
- 7
- 8
- 9
- 10

| | | | |
|-----------------------------|--------------|-----------------------|----------------|
| MACHINE & MODEL: | Case 988 | REFERENCE: | 99709 940608-1 |
| SERIAL No: | CGG0232265 | DATE OF CHART: | 27-Jan-2022 |
| EQUIPMENT: | 4.29m + 2.1m | SAFETY FACTOR: | 59.0% |
| COMMENT: | | | |



KING TRANSPORT EQUIPMENT LTD
Max Capacity Contours of Radius(m) Plots 2.1m Dipper
Gradient 1 in -25 Height 2m Lift QH
Locked Rail Cant 150mm - Tandem Lift

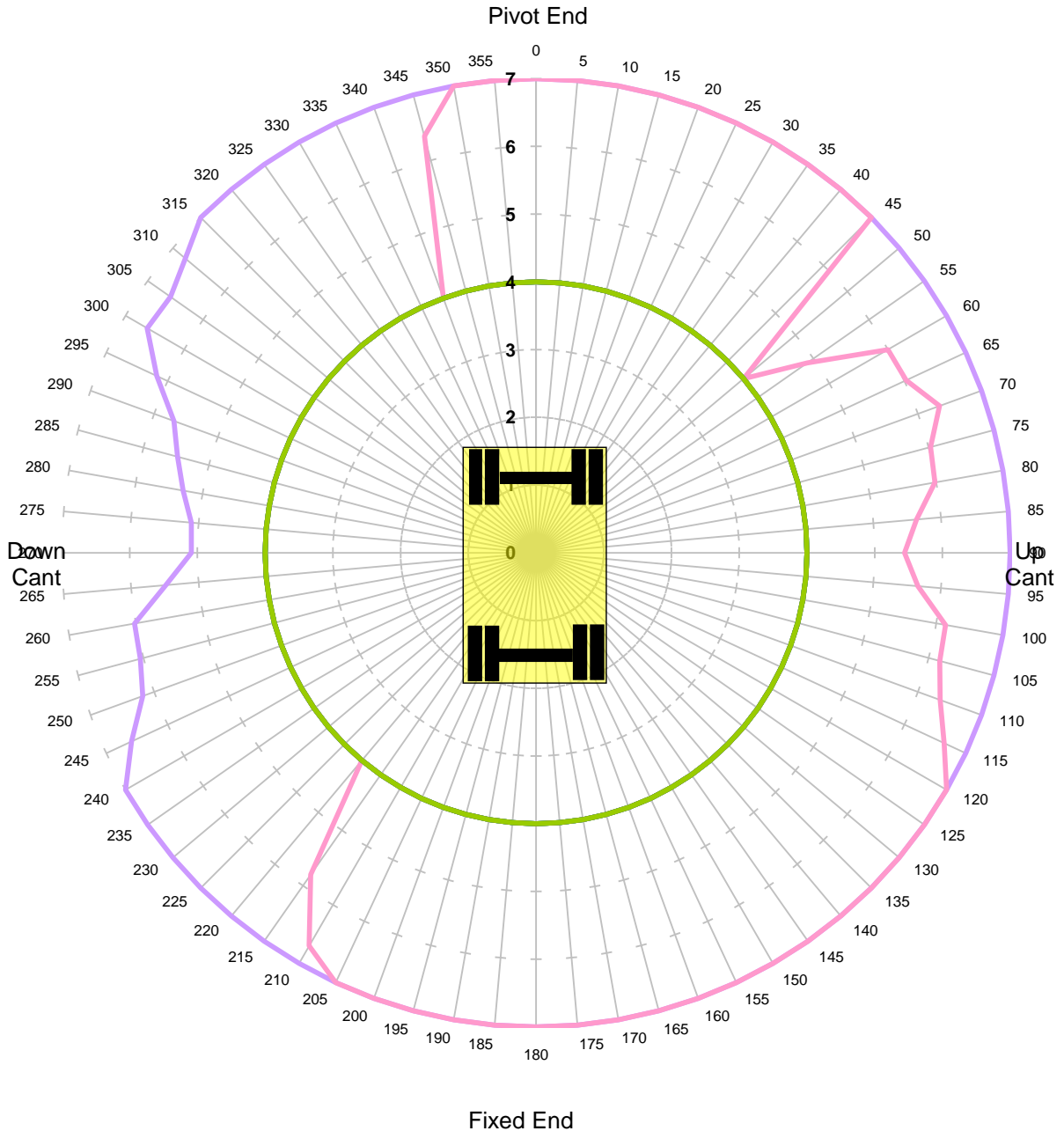

Units in Tonnes

- 1
- 2
- 3
- 4
- 5
- 6
- 7
- 8
- 9
- 10

| | | | |
|-----------------------------|--------------|-----------------------|----------------|
| MACHINE & MODEL: | Case 988 | REFERENCE: | 99709 940608-1 |
| SERIAL No: | CGG0232265 | DATE OF CHART: | 27-Jan-2022 |
| EQUIPMENT: | 4.29m + 2.1m | SAFETY FACTOR: | 59.0% |
| COMMENT: | | | |



KING TRANSPORT EQUIPMENT LTD
Max Capacity Contours of Radius(m) Plots 2.1m Dipper
Level Ground Height 2m Lift QH
Unlocked Road - Tandem Lift

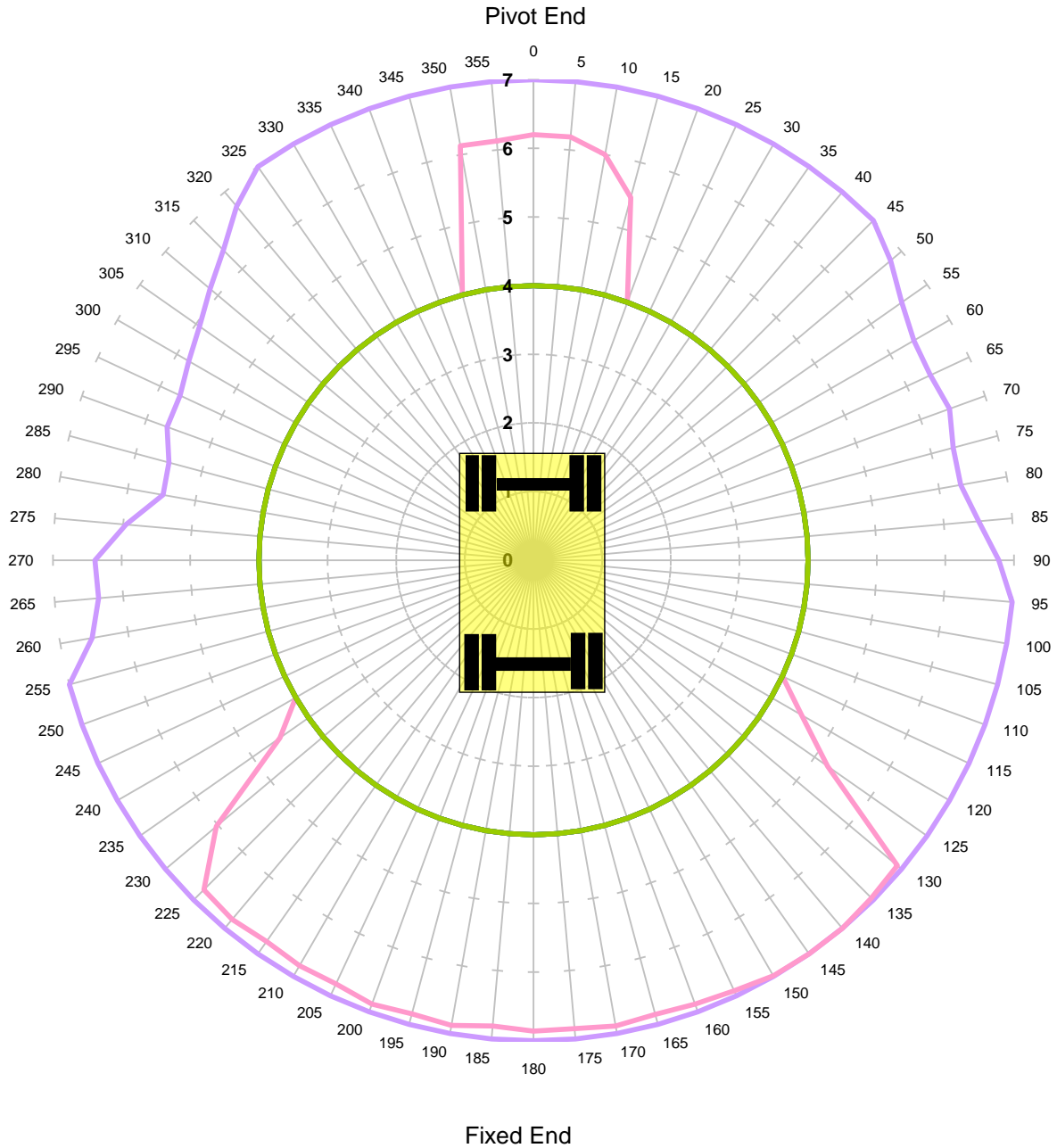

Units in Tonnes

- 1
- 2
- 3
- 4
- 5
- 6
- 7
- 8
- 9
- 10

| | | | |
|-----------------------------|--------------|-----------------------|----------------|
| MACHINE & MODEL: | Case 988 | REFERENCE: | 99709 940608-1 |
| SERIAL No: | CGG0232265 | DATE OF CHART: | 27-Jan-2022 |
| EQUIPMENT: | 4.29m + 2.1m | SAFETY FACTOR: | 50.0% |
| COMMENT: | | | |



KING TRANSPORT EQUIPMENT LTD
Max Capacity Contours of Radius(m) Plots 2.1m Dipper
Level Ground Height 2m Lift QH
Locked Road - Tandem Lift

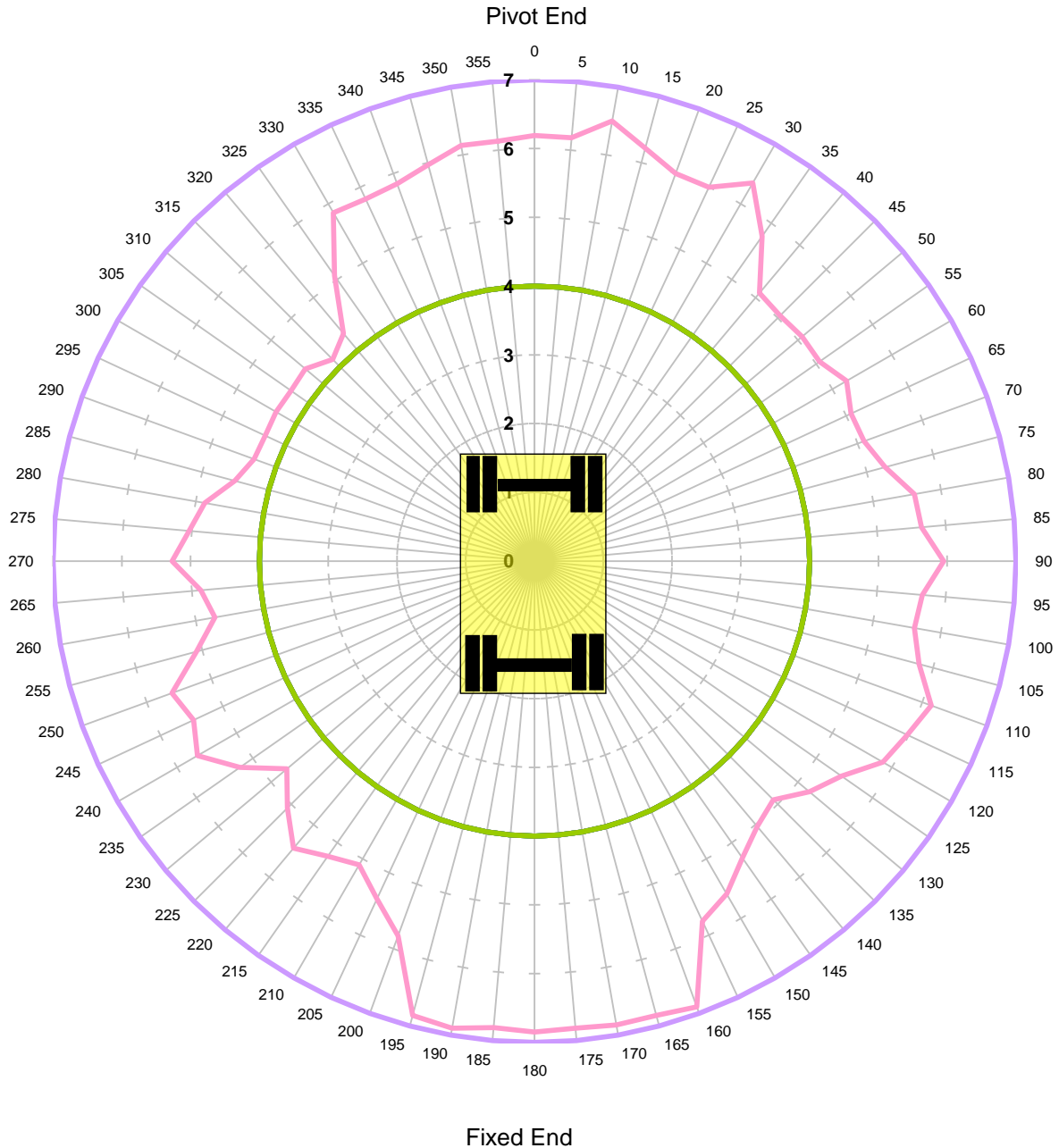

Units in Tonnes

- 1
- 2
- 3
- 4
- 5
- 6
- 7
- 8
- 9
- 10

| | | | |
|-----------------------------|--------------|-----------------------|----------------|
| MACHINE & MODEL: | Case 988 | REFERENCE: | 99709 940608-1 |
| SERIAL No: | CGG0232265 | DATE OF CHART: | 27-Jan-2022 |
| EQUIPMENT: | 4.29m + 2.1m | SAFETY FACTOR: | 50.0% |
| COMMENT: | | | |